

Sizing, Selection, and Installation of Pressure-Relieving Devices in Refineries

Part I—Sizing and Selection

API RECOMMENDED PRACTICE 520
SEVENTH EDITION, JANUARY 2000



Helping You
Get The Job
Done **Right.**SM



API ENVIRONMENTAL, HEALTH AND SAFETY MISSION AND GUIDING PRINCIPLES

The members of the American Petroleum Institute are dedicated to continuous efforts to improve the compatibility of our operations with the environment while economically developing energy resources and supplying high quality products and services to consumers. We recognize our responsibility to work with the public, the government, and others to develop and to use natural resources in an environmentally sound manner while protecting the health and safety of our employees and the public. To meet these responsibilities, API members pledge to manage our businesses according to the following principles using sound science to prioritize risks and to implement cost-effective management practices:

- To recognize and to respond to community concerns about our raw materials, products and operations.
- To operate our plants and facilities, and to handle our raw materials and products in a manner that protects the environment, and the safety and health of our employees and the public.
- To make safety, health and environmental considerations a priority in our planning, and our development of new products and processes.
- To advise promptly, appropriate officials, employees, customers and the public of information on significant industry-related safety, health and environmental hazards, and to recommend protective measures.
- To counsel customers, transporters and others in the safe use, transportation and disposal of our raw materials, products and waste materials.
- To economically develop and produce natural resources and to conserve those resources by using energy efficiently.
- To extend knowledge by conducting or supporting research on the safety, health and environmental effects of our raw materials, products, processes and waste materials.
- To commit to reduce overall emissions and waste generation.
- To work with others to resolve problems created by handling and disposal of hazardous substances from our operations.
- To participate with government and others in creating responsible laws, regulations and standards to safeguard the community, workplace and environment.
- To promote these principles and practices by sharing experiences and offering assistance to others who produce, handle, use, transport or dispose of similar raw materials, petroleum products and wastes.

Sizing, Selection, and Installation of Pressure-Relieving Devices in Refineries

Part I—Sizing and Selection

Downstream Segment

API RECOMMENDED PRACTICE 520
SEVENTH EDITION, JANUARY 2000



**Helping You
Get The Job
Done **Right**.SM**

SPECIAL NOTES

API publications necessarily address problems of a general nature. With respect to particular circumstances, local, state, and federal laws and regulations should be reviewed.

API is not undertaking to meet the duties of employers, manufacturers, or suppliers to warn and properly train and equip their employees, and others exposed, concerning health and safety risks and precautions, nor undertaking their obligations under local, state, or federal laws.

Information concerning safety and health risks and proper precautions with respect to particular materials and conditions should be obtained from the employer, the manufacturer or supplier of that material, or the material safety data sheet.

Nothing contained in any API publication is to be construed as granting any right, by implication or otherwise, for the manufacture, sale, or use of any method, apparatus, or product covered by letters patent. Neither should anything contained in the publication be construed as insuring anyone against liability for infringement of letters patent.

Generally, API standards are reviewed and revised, reaffirmed, or withdrawn at least every five years. Sometimes a one-time extension of up to two years will be added to this review cycle. This publication will no longer be in effect five years after its publication date as an operative API standard or, where an extension has been granted, upon republication. Status of the publication can be ascertained from the API Downstream Segment [telephone (202) 682-8000]. A catalog of API publications and materials is published annually and updated quarterly by API, 1220 L Street, N.W., Washington, D.C. 20005.

This document was produced under API standardization procedures that ensure appropriate notification and participation in the developmental process and is designated as an API standard. Questions concerning the interpretation of the content of this standard or comments and questions concerning the procedures under which this standard was developed should be directed in writing to the general manager of the Downstream Segment, American Petroleum Institute, 1220 L Street, N.W., Washington, D.C. 20005. Requests for permission to reproduce or translate all or any part of the material published herein should also be addressed to the general manager.

API standards are published to facilitate the broad availability of proven, sound engineering and operating practices. These standards are not intended to obviate the need for applying sound engineering judgment regarding when and where these standards should be utilized. The formulation and publication of API standards is not intended in any way to inhibit anyone from using any other practices.

Any manufacturer marking equipment or materials in conformance with the marking requirements of an API standard is solely responsible for complying with all the applicable requirements of that standard. API does not represent, warrant, or guarantee that such products do in fact conform to the applicable API standard.

All rights reserved. No part of this work may be reproduced, stored in a retrieval system, or transmitted by any means, electronic, mechanical, photocopying, recording, or otherwise, without prior written permission from the publisher. Contact the Publisher, API Publishing Services, 1220 L Street, N.W., Washington, D.C. 20005.

Copyright © 2000 American Petroleum Institute

FOREWORD

API Recommended Practice 520, *Sizing, Selection, and Installation of Pressure-Relieving Devices in Refineries*, is the result of several years' work by engineers in the petroleum industry.

The information in this recommended practice is intended to supplement the information contained in Section VIII, "Pressure Vessels," of the *ASME Boiler and Pressure Vessel Code*. The recommendations presented in this publication are not intended to supersede applicable laws and regulations.

Users of this recommended practice are reminded that no publication of this type can be complete, nor can any written document be substituted for qualified engineering analysis.

The current edition of this recommended practice, published in two parts, has been updated with respect to the practices generally used in the installation of all devices covered in the previous editions; the current edition also contains additional information based on revisions suggested by many individuals and several organizations.

The first edition of this recommended practice was issued in 1955. The second edition was published in two parts: Part I, "Design," in 1960 and Part II, "Installation," in 1963. The third edition of Part I was issued in November 1967 and reaffirmed in 1973. The fourth edition was issued in December 1976, the fifth edition was issued in July 1990, and the sixth edition was issued in March 1993.

API publications may be used by anyone desiring to do so. Every effort has been made by the Institute to assure the accuracy and reliability of the data contained in them; however, the Institute makes no representation, warranty, or guarantee in connection with this publication and hereby expressly disclaims any liability or responsibility for loss or damage resulting from its use or for the violation of any federal, state, or municipal regulation with which this publication may conflict.

Suggested revisions are invited and should be submitted to the general manager of the Downstream Segment, American Petroleum Institute, 1220 L Skeet, N.W., Washington, D.C. 20005.

CONTENTS

	Page
1 INTRODUCTION.....	1
1.1 Scope	1
1.2 Definition of Terms	1
1.3 Referenced Publications	4
2 PRESSURE RELIEF DEVICES.....	5
2.1 General	5
2.2 Pressure Relief Valves	5
2.3 Rupture Disk Devices	16
2.4 Pin-Actuated Devices	28
2.5 Other Types of Devices	30
3 PROCEDURES FOR SIZING	30
3.1 Determination of Relief Requirements	30
3.2 API Effective Area and Effective Coefficient of Discharge	32
3.3 Back Pressure	34
3.4 Cold Differential Test Pressure (CDTP)	38
3.5 Relieving Pressure	39
3.6 Sizing for Gas or Vapor Relief	41
3.7 Sizing for Steam Relief	50
3.8 Sizing for Liquid Relief: Pressure Relief Valves Requiring Capacity Certification	52
3.9 Sizing for Liquid Relief Pressure Relief Valves Not Requiring Capacity Certification	53
3.10 Sizing for Two-Phase Liquid/Vapor Relief	55
3.11 Sizing for Rupture Disk Devices	55
4 REFERENCES	56
APPENDIX A RUPTURE DISK DEVICE SPECIFICATION SHEET.....	57
APPENDIX B REVIEW OF FLOW EQUATIONS USED IN SIZING PRESSURE RELIEF VALVES FOR GAS OR VAPOR	61
APPENDIX C PRESSURE RELIEF VALVE SPECIFICATION SHEETS	63
APPENDIX D SIZING FOR TWO-PHASE LIQUID/VAPOR RELIEF.....	69
APPENDIX E CAPACITY EVALUATION OF RUPTURE DISK AND PIPING SYSTEM 100% VAPOR FLOW AND CONSTANT PIPE DIAMETER	83

Figures

1 Pressure-Level Relationships for Pressure Relief Valves.....	3
2 Conventional Pressure Relief Valve with a Single Adjusting Ring for Blowdown Control	6
3 Balanced-Bellows Pressure Relief Valve	7
4 Balanced-Bellows Pressure Relief Valve with an Auxiliary Balanced Piston.....	9
5 Conventional Pressure Relief Valve with Threaded Connections	10
6 Pop-Action Pilot-Operated Valve (Flowing-Type).....	11
7 Pop-Action Pilot-Operated Valve (Nonflowing-Type)	12

	Page
8 Modulating Pilot-Operated Valve (Flowing-Type).....	13
9 Pilot-Operated Relief Valve with a Nonflowing Modulating Pilot Valve	14
10 Low-Pressure Pilot-Operated Valve (Diaphragm-Type)	15
11 Forward-Acting Solid Metal Rupture Disk	17
12 Forward-Acting Scored Rupture Disk	19
13 Forward-Acting Composite Rupture Disk	20
14 Reverse-Acting Rupture Disk with Knife Blades.....	22
15 Reverse-Acting Scored Rupture Disk.....	23
16 Graphite Rupture Disk	24
17 Rupture Disk Device in Combination with a Pressure Relief Valve	25
18 Buckling Pin Valve	26
19 Pressure Relief Valve Operation—Vapor/Gas Service.....	27
20 Typical Relationship Between Lift of Disk in a Pressure Relief Valve and Vessel Pressure	28
21 Pressure Relief Valve Operation—Liquid Service.....	28
22 Typical Effects of Superimposed Back Pressure on the Opening Pressure of Conventional Pressure Relief Valves	29
23 Typical Effects of Back Pressure on the Set Pressure of Balanced Pressure Relief Valves	29
24 Typical Relationship Between Lift of Disk or Piston and Vessel Pressure in a Pop-Action Pilot-Operated Pressure Relief Valve.....	30
25 Typical Relationship Between Lift of Disk or Piston and Vessel Pressure in a Modulating-Action Pilot-Operated Pressure Relief Valve	30
26 Pressure-Level Relationships for Rupture Disk Devices.....	31
27 Common Types of Manufacturing Ranges and Corresponding Burst Pressure Marking.....	32
28 Rupture Disk Application Parameters.....	33
29 Rupture Disk Application Parameters.....	35
30 Back Pressure Correction Factor, K_b , for Balanced-Bellows Pressure Relief Valve (Vapors and Gases).....	37
31 Capacity Correction Factor, K_{vs} , Due to Back Pressure on Balanced-Bellows Pressure Relief Valves in Liquid Service	38
32 Curve for Evaluating Coefficient C in the Flow Equation from the Specific Heat Ratio Assuming Ideal Gas Behavior	44
33 Sample of Completed Pressure Relief Valve Specification Sheet	46
34 Values of F_2 for Subcritical Flow	48
35 Constant Back Pressure Correction Factor, K_b , for Conventional Pressure Relief Valves (Vapors and Gases Only)	49
36 Capacity Correction Factor, K_v , Due to Viscosity.....	54
37 Capacity Correction Factors Due to Overpressure for Noncertified Pressure Relief Valves in Liquid Service.....	55
A-1 Rupture Disk Device Specification Sheet.....	60
C-1 Spring-Loaded Pressure Relief Valve Specification Sheet.....	65
C-2 Pilot-Operated Pressure Relief Valve Specification Sheet.....	68
D-1 Correlation for Nozzle Critical Flow of Flashing and Nonflashing Systems	78
D-2 Back Pressure Correction Factor, K_b , for Balanced-Bellows Pressure Relief Valves (Vapors and Gases)	79
D-3 Correlation for Nozzle Critical Flow of Inlet Subcooled Liquids	80
D-4 Back Pressure Correction Factor, K_b , for Balanced-Bellows Pressure Relief Valves (Liquids)	81
E-1 Pressure Relief System for Example Problem	84
E-2 Curve Fit for $C_p/C_v = 1.4$ (Crane Figure A-22)	85

	Page
Tables	
1	Set Pressure and Accumulation Limits for Pressure Relief Valves 39
2	Example Determination of Relieving Pressure for a Single-Valve Installation (Operating Contingencies) 40
3	Example Determination of Relieving Pressure for a Multiple-Valve Installation (Operating Contingencies) 40
4	Example Determination of Relieving Pressure for a Single-Valve Installation (Fire Contingencies) 41
5	Example Determination of Relieving Pressure for a Multiple-Valve Installation (Fire Contingencies) 41
6	Example Determination of Relieving Pressure for a Supplemental-Valve Installation (Fire Contingencies) 41
7	Properties of Gases 43
8	Values of Coefficient C 50
9	Superheat Correction Factors, K_{SH} 51
D-1	Two-Phase Liquid/Vapor Relief Scenarios for Pressure Relief Valves 69

Sizing, Selection, and Installation of Pressure-Relieving Devices in Refineries

Part I—Sizing and Selection

1 Introduction

1.1 SCOPE

This recommended practice applies to the sizing and selection of pressure relief devices used in refineries and related industries for equipment that has a maximum allowable working pressure of 15 psig [103 kPag] or greater. The pressure relief devices covered in this recommended practice are intended to protect unfired pressure vessels and related equipment against overpressure from operating and fire contingencies.

This recommended practice includes basic definitions and information about the operational characteristics and applications of various pressure relief devices. It also includes sizing procedures and methods based on steady state flow of Newtonian fluids.

Pressure relief devices protect a vessel against overpressure only; they do not protect against structural failure when the vessel is exposed to extremely high temperatures such as during a fire. See API Recommended Practice 521 for information about appropriate ways of reducing pressure and restricting heat input.

Atmospheric and low pressure storage tanks covered in API Standard 2000 and pressure vessels used for the transportation of products in bulk or shipping containers are not within the scope of this recommended practice.

The rules for overpressure protection of fired vessels are provided in Section I of the ASME *Boiler and Pressure Vessel Code* and ASME B31.1, and are not within the scope of this recommended practice.

1.2 DEFINITION OF TERMS

Terms used in this recommended practice relating to pressure relief devices and their dimensional and operational characteristics are defined in 1.2.1 through 1.2.3. The terms are covered more specifically in the applicable sections of text and accompanying illustrations.

1.2.1 Pressure Relief Devices

1.2.1.1 pressure relief device: Actuated by inlet static pressure and designed to open during emergency or abnormal conditions to prevent a rise of internal fluid pressure in excess of a specified design value. The device also may be designed to prevent excessive internal vacuum. The device may be a pressure relief valve, a non-reclosing pressure relief device, or a vacuum relief valve.

1.2.1.2 pressure relief valve: A pressure relief device designed to open and relieve excess pressure and to reclose and prevent the further flow of fluid after normal conditions have been restored.

a. A *relief valve* is a spring loaded pressure relief valve actuated by the static pressure upstream of the valve. The valve opens normally in proportion to the pressure increase over the opening pressure. A relief valve is used primarily with incompressible fluids.

b. A *safety valve* is a spring loaded pressure relief valve actuated by the static pressure upstream of the valve and characterized by rapid opening or pop action. A safety valve is normally used with compressible fluids.

c. A *safety relief valve* is a spring loaded pressure relief valve that may be used as either a safety or relief valve depending on the application.

d. A *conventional pressure relief valve* is a spring loaded pressure relief valve whose operational characteristics are directly affected by changes in the back pressure.

e. A *balanced pressure relief valve* is a spring loaded pressure relief valve that incorporates a bellows or other means for minimizing the effect of back pressure on the operational characteristics of the valve.

f. A *pilot operated pressure relief valve* is a pressure relief valve in which the major relieving device or main valve is combined with and controlled by a self actuated auxiliary pressure relief valve (pilot).

1.2.1.3 non-reclosing pressure relief device: A pressure relief device which remains open after operation. A manual resetting means may be provided.

1.2.1.4 rupture disk device: A non-reclosing pressure relief device actuated by static differential pressure between the inlet and outlet of the device and designed to function by the bursting of a rupture disk. A rupture disk device includes a rupture disk and a rupture disk holder.

a. A *rupture disk* is a pressure containing, pressure and temperature sensitive element of a rupture disk device.

b. A *rupture disk holder* is the structure which encloses and clamps the rupture disk in position. (Some disks are designed to be installed between standard flanges without holders.)

c. A *nonfragmenting rupture disk* is a rupture disk designed and manufactured to be installed upstream of other piping components, such as pressure relief valves, and will not impair the function of those components when the disk ruptures.

1.2.1.5 pin-actuated device: A non-reclosing pressure relief device actuated by static pressure and designed to function by buckling or breaking a pin which holds a piston or a plug in place. Upon buckling or breaking of the pin, the piston or plug instantly moves to the full open position.

1.2.2 Dimensional Characteristics of Pressure Relief Devices

1.2.2.1 actual discharge area: The minimum net area that determines the flow through a valve.

1.2.2.2 curtain area: The area of the cylindrical or conical discharge opening between the seating surfaces above the nozzle seat created by the lift of the disc.

1.2.2.3 effective discharge area: A nominal or computed area used with an effective discharge coefficient to calculate the minimum required relieving capacity for a pressure relief valve per the preliminary sizing equations contained in this practice. API Standard 526 provides effective discharge areas for a range of sizes in terms of letter designations, "D" through "T".

1.2.2.4 bore area: The minimum cross-sectional flow area of a nozzle. Also referred to as nozzle area, nozzle throat area and throat area.

1.2.2.5 huddling chamber: An annular chamber located downstream of the seat of a pressure relief valve for the purpose of assisting the valve to achieve lift.

1.2.2.6 inlet size: The nominal pipe size (NPS) of the valve at the inlet connection, unless otherwise designated.

1.2.2.7 outlet size: The nominal pipe size (NPS) of the valve at the discharge connection, unless otherwise designated.

1.2.2.8 lift: The actual travel of the disc from the closed position when a valve is relieving.

1.2.2.9 minimum net flow area: The calculated net area after a complete burst of a rupture disc with appropriate allowance for any structural members which may reduce the net flow area through the rupture disk device. The net flow area for sizing purposes shall not exceed the nominal pipe size area of the rupture disk device.

1.2.3 Operational Characteristics

1.2.3.1 coefficient of discharge: The ratio of the mass flow rate in a valve to that of an ideal nozzle. It is used for calculating flow through a pressure relief device.

a. The *effective coefficient of discharge* is a nominal value used with an effective discharge area to calculate the minimum required relieving capacity of a pressure relief valve. This capacity is determined in accordance with the applicable

per the preliminary sizing equations given in this Recommended Practice.

b. The *rated coefficient of discharge* is determined in accordance with the applicable code or regulation and is used with the actual discharge area to calculate the rated flow capacity of a pressure relief valve.

1.2.3.2 System Pressures and Temperatures (See Figures 1 and 26 for further clarification of these pressure related terms.)

a. The *maximum operating pressure* is the maximum pressure expected during normal system operation.

b. The *maximum allowable working pressure (MAWP)* is the maximum gauge pressure permissible at the top of a completed vessel in its normal operating position at the designated coincident temperature specified for that pressure. The pressure is the least of the values for the internal or external pressure as determined by the vessel design rules for each element of the vessel using actual nominal thickness, exclusive of additional metal thickness allowed for corrosion and loadings other than pressure. The maximum allowable working pressure is the basis for the pressure setting of the pressure relief devices that protect the vessel. The MAWP is normally greater than the design pressure but must be equal to the design pressure when the design rules are used only to calculate the minimum thickness for each element and calculations are not made to determine the value of the MAWP.

c. The *design pressure* of the vessel along with the design temperature is used to determine the minimum permissible thickness or physical characteristic of each vessel component as determined by the vessel design rules. The design pressure is selected by the user to provide a suitable margin above the most severe pressure expected during normal operation at a coincident temperature. It is the pressure specified on the purchase order. This pressure may be used in place of the maximum allowable working pressure in all cases where the MAWP has not been established. The design pressure is equal to or less than the MAWP.

d. *Accumulation* is the pressure increase over the maximum allowable working pressure of the vessel allowed during discharge through the pressure relief device, expressed in pressure units or as a percentage of MAWP or design pressure. Maximum allowable accumulations are established by applicable codes for emergency operating and fire contingencies.

e. *Overpressure* is the pressure increase over the set pressure of the relieving device allowed to achieve rated flow. Overpressure is expressed in pressure units or as a percentage of set pressure. It is the same as accumulation only when the relieving device is set to open at the maximum allowable working pressure of the vessel.

f. The *rated relieving capacity* is the relieving capacity used as the basis for the application of a pressure relief device. code or regulation and is provided by the manufacturer.

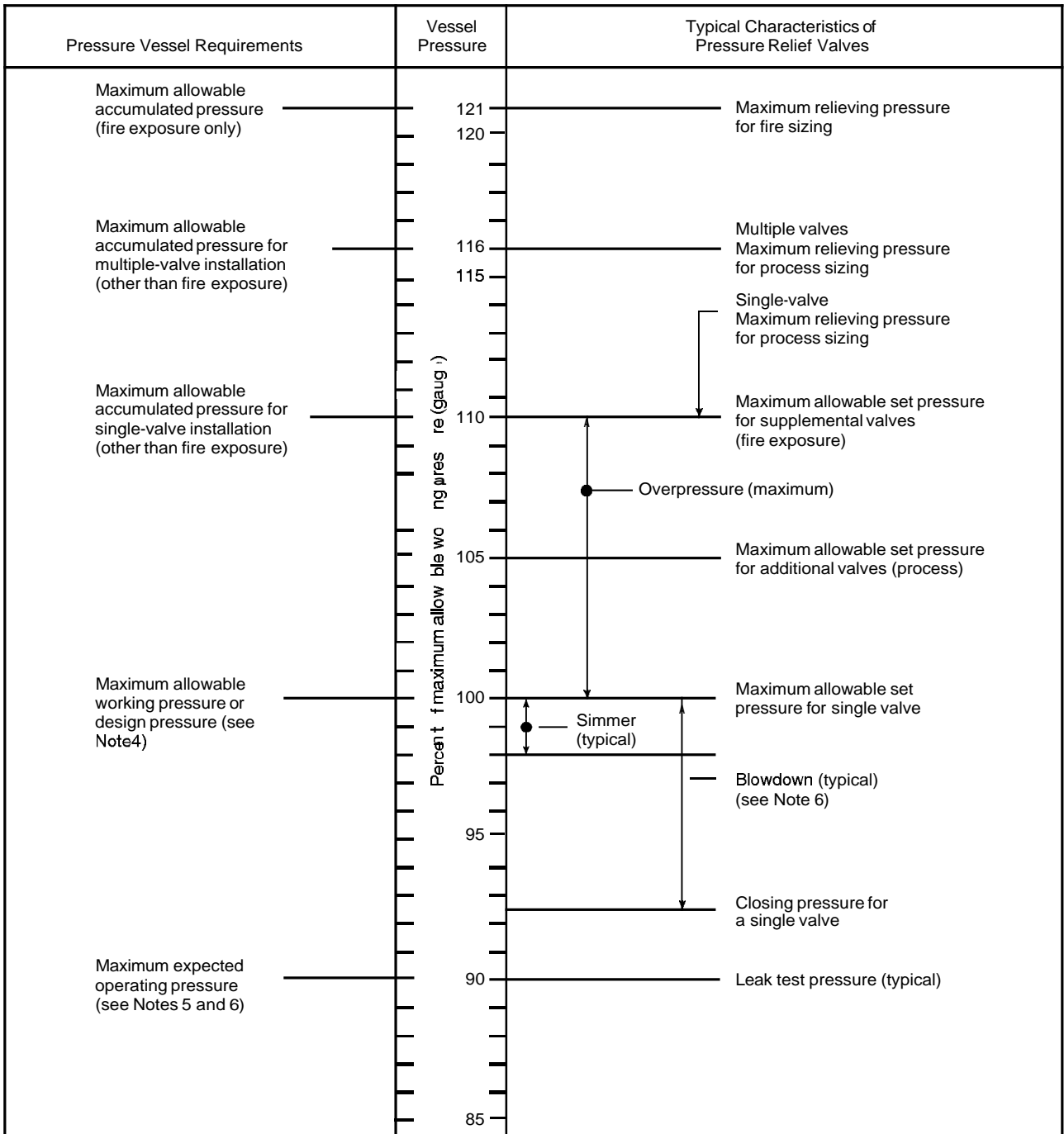

Notes:

1. This figure conforms with the requirements of Section VIII of the ASME *Boiler and Pressure Vessel Code* for MAWPs greater than 30 psi.
2. The pressure conditions shown are for pressure relief valves installed on a pressure vessel.
3. Allowable set-pressure tolerances will be in accordance with the applicable codes.
4. The maximum allowable working pressure is equal to or greater than the design pressure for a coincident design temperature.
5. The operating pressure may be higher or lower than 90.
6. Section VIII, Division 1, Appendix M of the ASME Code should be referred to for guidance on blowdown and pressure differentials.

Figure 1—Pressure-Level Relationships for Pressure Relief Valves

Note: The capacity marked on the device is the rated capacity on steam, air, gas or water as required by the applicable code.

1.2.3.3 Device Pressures (See Figures 1, 26, 27, 28, and 29 for further clarification of these pressure related terms.)

- a. The *set pressure* is the inlet gauge pressure at which the pressure relief device is set to open under service conditions.
- b. The *cold differential test pressure (CDTP)* is the pressure at which a pressure relief valve is adjusted to open on the test stand. The cold differential test pressure includes corrections for the service conditions of back pressure or temperature or both.
- c. The *burst pressure* of a rupture disk at the specified temperature is the value of the upstream static pressure minus the value of the downstream static pressure just prior to when the disk bursts. When the downstream pressure is atmospheric, the burst pressure is the upstream static gauge pressure.
- d. The *marked burst pressure*, or rated burst pressure of a rupture disk, is the burst pressure established by tests for the specified temperature and marked on the disk tag by the manufacturer. The marked burst pressure may be any pressure within the manufacturing range unless otherwise specified by the customer. The marked burst pressure is applied to all of the rupture disks of the same lot.
- e. The *specified burst pressure* is the burst pressure specified by the user. The marked burst pressure may be greater than or less than the specified burst pressure but shall be within the manufacturing range. The user is cautioned to consider manufacturing range, superimposed back pressure and specified temperature when determining a specified burst pressure.
- f. *Burst-pressure tolerance* is the variation around the marked burst pressure at the specified disk temperature in which a rupture disk shall burst.
- g. A *lot of rupture disks* is those disks manufactured at the same time and of the same size, material, thickness, type, heat and manufacturing process, including heat treatment.
- h. The *manufacturing range* is the pressure range in which the rupture disk shall be marked. Manufacturing ranges are usually catalogued by the manufacturer as a percentage of the specified burst pressure. Catalogued manufacturing ranges may be modified by agreement between the user and the manufacturer.
- i. *Back pressure* is the pressure that exists at the outlet of a pressure relief device as a result of the pressure in the discharge system. It is the sum of the superimposed and built-up back pressures.
- j. *Built-up back pressure* is the increase in pressure at the outlet of a pressure relief device that develops as a result of flow after the pressure relief device opens.
- k. *Superimposed back pressure* is the static pressure that exists at the outlet of a pressure relief device at the time the device is required to operate. It is the result of pressure in the discharge system coming from other sources and may be constant or variable.

l. *Blowdown* is the difference between the set pressure and the closing pressure of a pressure relief valve, expressed as a percentage of the set pressure or in pressure units.

m. *Opening pressure* is the value of increasing inlet static pressure at which there is a measurable lift of the disc or at which discharge of the fluid becomes continuous, as determined by seeing, feeling or hearing.

n. *Closing Pressure* is the value of decreasing inlet static pressure at which the valve disc reestablishes contact with the seat or at which lift becomes zero as determined by seeing, feeling or hearing.

o. *Simmer* is the audible or visible escape of compressible fluid between the seat and disc which may occur at an inlet static pressure below the set pressure prior to opening.

p. The *operating ratio* of a pressure relief valve is the ratio of maximum system operating pressure to the set pressure.

q. The *operating ratio* of a rupture disk is the ratio of the maximum system operating pressure to a pressure associated with a rupture disk as follows (see Figures 28 and 29):

1. For marked burst pressures above 40 psi: The operating ratio is the ratio of maximum system operating pressure to the disk marked burst pressure.
2. For marked burst pressures of 40 psi and below: The operating ratio is the ratio of maximum system operating pressure to the marked burst pressure minus 2 psi.

r. *Leak-test pressure* is the specified inlet static pressure at which a seat leak test is performed.

s. The term *relieving conditions* is used to indicate the inlet pressure and temperature on a pressure relief device during an overpressure condition. The relieving pressure is equal to the valve set pressure (or rupture disk burst pressure) plus the overpressure. (The temperature of the flowing fluid at relieving conditions may be higher or lower than the operating temperature.)

t. The *specified disk temperature* of a rupture disk shall be the temperature of the disk when the disk is expected to burst. It is the temperature the manufacturer uses to establish the marked burst pressure. The specified disk temperature is rarely ever the design temperature of the vessel and may not even be the operating temperature or relief temperature, depending on the relief system configuration.

1.3 REFERENCED PUBLICATIONS

The current editions of the following standards, codes, and specifications are cited in this recommended practice:

API

- | | |
|---------|---|
| RP 520 | <i>Sizing, Selection, and Installation of Pressure-Relieving Devices in Refineries, Part II, "Installation"</i> |
| Std 526 | <i>Flanged Steel Pressure Relief Valves</i> |

- Std 510 *Pressure Vessel Inspection Code—Maintenance Inspection, Rating, Repair; and Alteration*
- RP 521 *Guide for Pressure-Relieving and Depressurizing Systems*
- Std 527 *Seat Tightness of Pressure Relief Valves*
- RP 576 *Inspection of Pressure-Relieving Devices*
- Std 2000 *Venting Atmospheric and Low-Pressure Storage Tanks (Nonrefrigerated and Refrigerated).*

ASME¹

- Boiler and Pressure Vessel Code, Section I, "Power Boilers,"* 1998
- Boiler and Pressure Vessel Code, Section VIII, "Pressure Vessels,"* Division 1, 1998
- B31.1 *Power Piping,* 1995, latest addenda
- B31.3 *Process Piping,* 1996, latest addenda

2 Pressure Relief Devices

2.1 GENERAL

This section describes the basic principles, operational characteristics, applications, and selection of pressure relief devices used independently or in combination. These devices include spring loaded and pilot operated pressure relief valves, rupture disk devices, and other pressure relief devices. These devices are described in the text and illustrated in Figures 2–18.

2.2 PRESSURE RELIEF VALVES

2.2.1 Spring-Loaded Pressure Relief Valves

2.2.1.1 Conventional Pressure Relief Valves

2.2.1.1.1 A conventional pressure relief valve (see Figures 2 and 5) is a self-actuated spring-loaded pressure relief valve which is designed to open at a predetermined pressure and protect a vessel or system from excess pressure by removing or relieving fluid from that vessel or system. The valve shown in Figure 5 is available in small sizes commonly used for thermal relief valve applications. The basic elements of a spring-loaded pressure relief valve include an inlet nozzle connected to the vessel or system to be protected, a movable disc which controls flow through the nozzle, and a spring which controls the position of the disc. Under normal system operating conditions, the pressure at the inlet is below the set pressure and the disc is seated on the nozzle preventing flow through the nozzle.

¹American Society of Mechanical Engineers, 345 East 47th Street, New York, New York 10017.

2.2.1.1.2 Spring-loaded pressure relief valves are referred to by a variety of terms, such as safety valves, relief valves and safety relief valves. These terms have been traditionally applied to valves for gas/vapor service, liquid service, or multi-service applications, respectively. The more generic term, pressure relief valve, is used in the text and is applicable to all three.

2.2.1.1.3 The operation of a conventional spring-loaded pressure relief valve is based on a force balance (see Figure 19). The spring-load is preset to equal the force exerted on the closed disc by the inlet fluid when the system pressure is at the set pressure of the valve. When the inlet pressure is below the set pressure, the disc remains seated on the nozzle in the closed position. When the inlet pressure exceeds set pressure, the pressure force on the disc overcomes the spring force and the valve opens. When the inlet pressure is reduced to a level below the set pressure, the valve re-closes.

2.2.1.1.4 When the valve is closed during normal operation, see Figure 19A, the system or vessel pressure acting against the disc surface (area "A") is resisted by the spring force. As the system pressure approaches the set pressure of the valve, the seating force between the disc and the nozzle approaches zero.

2.2.1.1.5 In vapor or gas service, the valve may "simmer" before it will "pop." When the vessel pressure closely approaches the set pressure, fluid will audibly move past the seating surfaces into the huddling chamber "B." As a result of the restriction of flow between the disc holder and the adjusting ring, pressure builds up in the huddling chamber B (see Figure 19B). Since pressure now acts over a larger area, an additional force, commonly referred to as the expansive force, is available to overcome the spring force. By adjusting the adjusting ring, the opening in the annular orifice can be altered, thus controlling the pressure build-up in the huddling chamber "B." This controlled pressure build-up in the huddling chamber will overcome the spring force causing the disc to move away from the nozzle seat, and the valve will pop open.

2.2.1.1.6 Once the valve has opened, an additional pressure build-up at C occurs (see Figure 19C). This is due to the sudden flow increase and the restriction to flow through another annular orifice formed between the inner edge of the disc holder skirt and the outside diameter of the adjusting ring. These additional forces at "C" cause the disc to lift substantially at pop.

2.2.1.1.7 Flow is restricted by the opening between the nozzle and the disc until the disc has been lifted from the nozzle seat approximately one quarter of the nozzle diameter. After the disc has attained this degree of lift, flow is then controlled by the bore area rather than by the area between the seating surfaces.

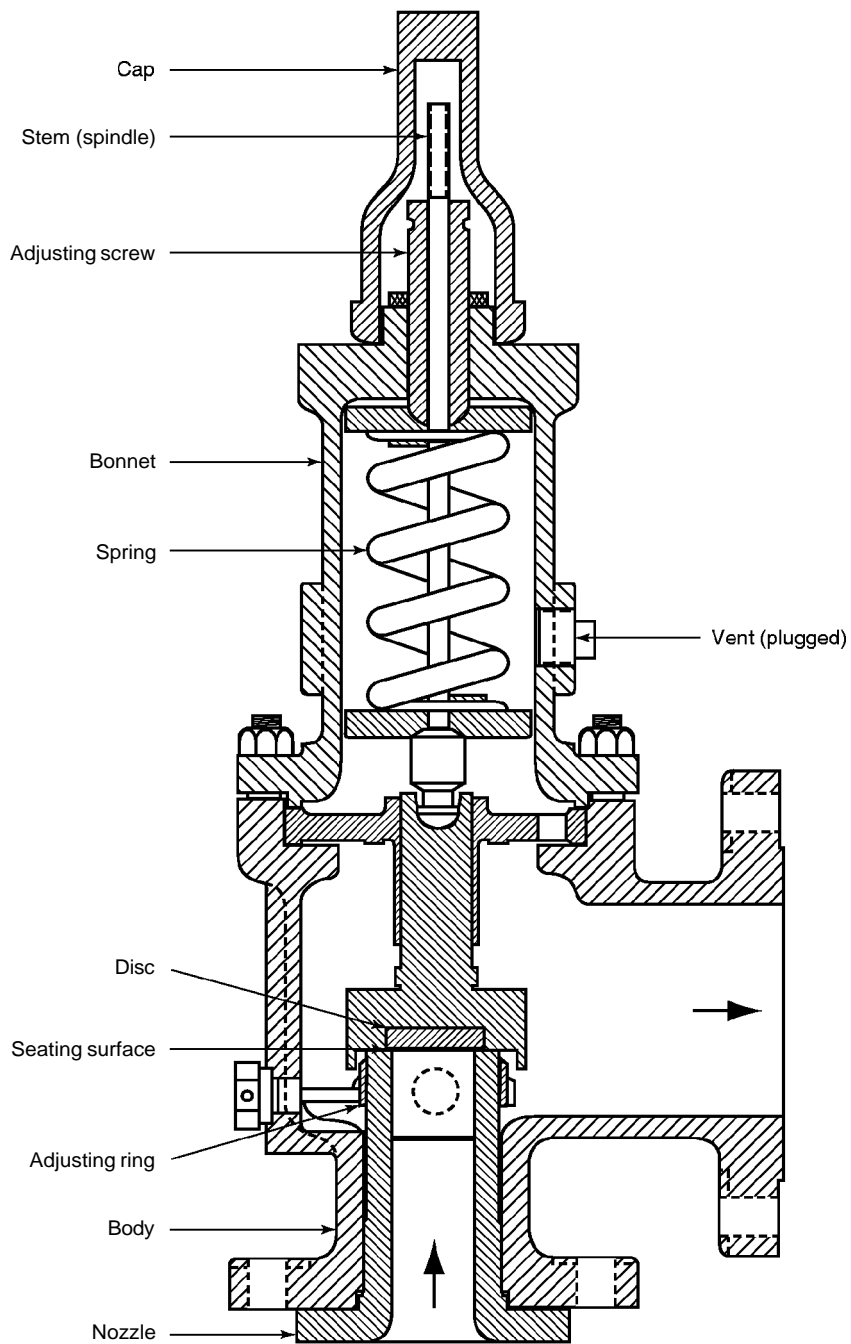

Figure 2—Conventional Pressure Relief Valve with a Single Adjusting Ring for Blowdown Control

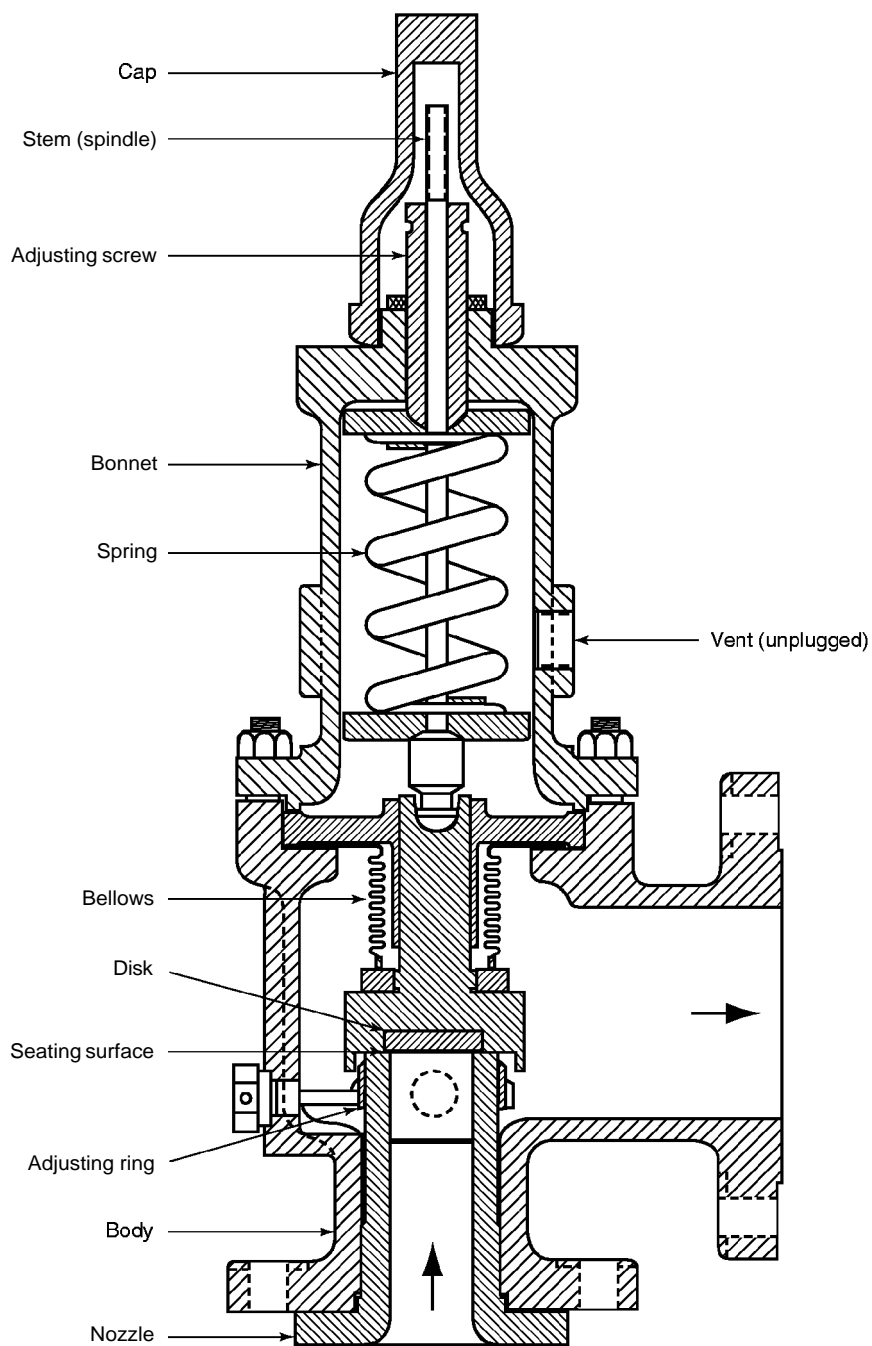

Figure 3—Balanced-Bellows Pressure Relief Valve

2.2.1.1.8 The valve closes when the inlet pressure has dropped sufficiently below the set pressure to allow the spring force to overcome the summation of forces at A, B, and C. The pressure at which the valve re-seats is the closing pressure. The difference between the set pressure and the closing pressure is blowdown.

2.2.1.1.9 Figure 20 shows the disc travel from the set pressure, A, to the maximum relieving pressure, B, during the overpressure incident and to the closing pressure, C, during the blowdown.

2.2.1.2 Spring-Loaded Pressure Relief Valves Designed for Liquid Service Applications

2.2.1.2.1 Liquid service valves do not pop in the same manner as vapor service valves (see Figure 21), since the expansive forces produced by vapor are not present in liquid flow. Liquid service valves must necessarily rely on reactive forces to achieve lift.

2.2.1.2.2 When the valve is closed, the forces acting on the valve disc are the same as those applied by vapor until a force balance is reached and the net force holding the seat closed approaches zero. From this point on, the force relationship is totally different.

2.2.1.2.3 At initial opening, the escaping liquid forms a very thin sheet of fluid, as seen in Figure 21A, expanding radially between the seating surfaces. The liquid strikes the reaction surface of the disc holder and is deflected downward, creating a reactive (turbine) force tending to move the disc and holder upward. These forces typically build very slowly during the first 2% – 4% of overpressure.

2.2.1.2.4 As the flow gradually increases, the velocity head of the liquid moving through the nozzle also increases. These momentum forces, combined with the reactive forces of the radially discharging liquid as it is deflected downward from the reaction surface (see Figure 21B), are substantial enough to cause the valve to go into lift. Typically the valve will suddenly surge to 50% – 100% lift at 2% – 6% overpressure. As the overpressure increases, these forces continue to grow, driving the valve into full lift. Liquid service valves, capacity certified by ASME, are required to reach full rated capacity at 10% or less overpressure.

2.2.1.2.5 In the closing cycle, as the overpressure decreases, momentum and reactive forces decrease, allowing the spring force to move the disc back into contact with the seat.

2.2.1.2.6 Historically, many pressure relief valves used in liquid applications were safety relief or relief valves designed for compressible (vapor) service. Many of these valves, when used in liquid service, required high overpressure (25%) to achieve full lift and stable operation, since liquids do not pro-

vide the expansive forces that vapors do. Where liquid pressure relief valves were required to operate within the accumulation limit of 10%, a conservative factor of 0.6 was applied to the valve capacity when sizing the valves. Consequently, many installations were oversized and instability often resulted. The criteria used for sizing this type of valve may be found in 3.9.

2.2.1.2.7 Rules have been incorporated into the ASME *Boiler and Pressure Vessel Code*, Section VIII, as well as other international standards which address performance of liquid service valves at 10% overpressure and which require a capacity certification. Pressure relief valves designed for liquid service have been developed which achieve full lift, stable operation, and rated capacity at 10% overpressure in compliance with the requirements. Blowdown is adjustable in some designs. Some valves are designed so that they operate on liquid and gas. Such valves, may however, exhibit different operational characteristics, depending on whether the flow stream is liquid, gas, or a combination of the two. Many pressure relief valves designed for liquid service, for example, will have a much longer blowdown (typically 20%) on gas than on liquid service. Additionally, some variation in set pressure may occur if the valve is set on liquid and required to operate on gas or vice versa.

2.2.1.2.8 The rules for sizing pressure relief valves designed for liquid service are given in 3.8. If a capacity on gas service is required, 3.6.2 or 3.6.3 should be used for the preliminary sizing calculation. Capacity certification data for sizing on liquid and gas service should be obtained from the manufacturer for use in final sizing and application of the valve.

2.2.1.2.9 Spring-loaded pressure relief valves designed for liquid (or liquid and gas) applications and which are balanced to minimize the effects of back pressure are recommended for two phase applications when the fluid being relieved may be liquid, gas, or a multi-phase mixture. Many manufacturers recommend that valves designed for liquid or liquid-and-gas service be used if the mass percentage of the two phase mixture at the valve inlet is 50% vapor or less. In addition, if the ratio of liquid to gas in the flow stream is not certain, a valve specifically designed for liquid service or for service on liquid and gas should be used.

2.2.1.2.10 Pressure relief valves designed for liquid and gas service should be specified for the fluid the valve is normally exposed to. For example, if a liquid and gas service valve is located in the vapor region of a vessel containing a liquid level, the valve should be specified for gas service. The valve capacity stamped on the nameplate will be in SCFM of air. If a liquid and gas service valve is located on the water side of a heat exchanger, then the valve should be specified in liquid service. This valve will have a capacity stamped in GPM of water.

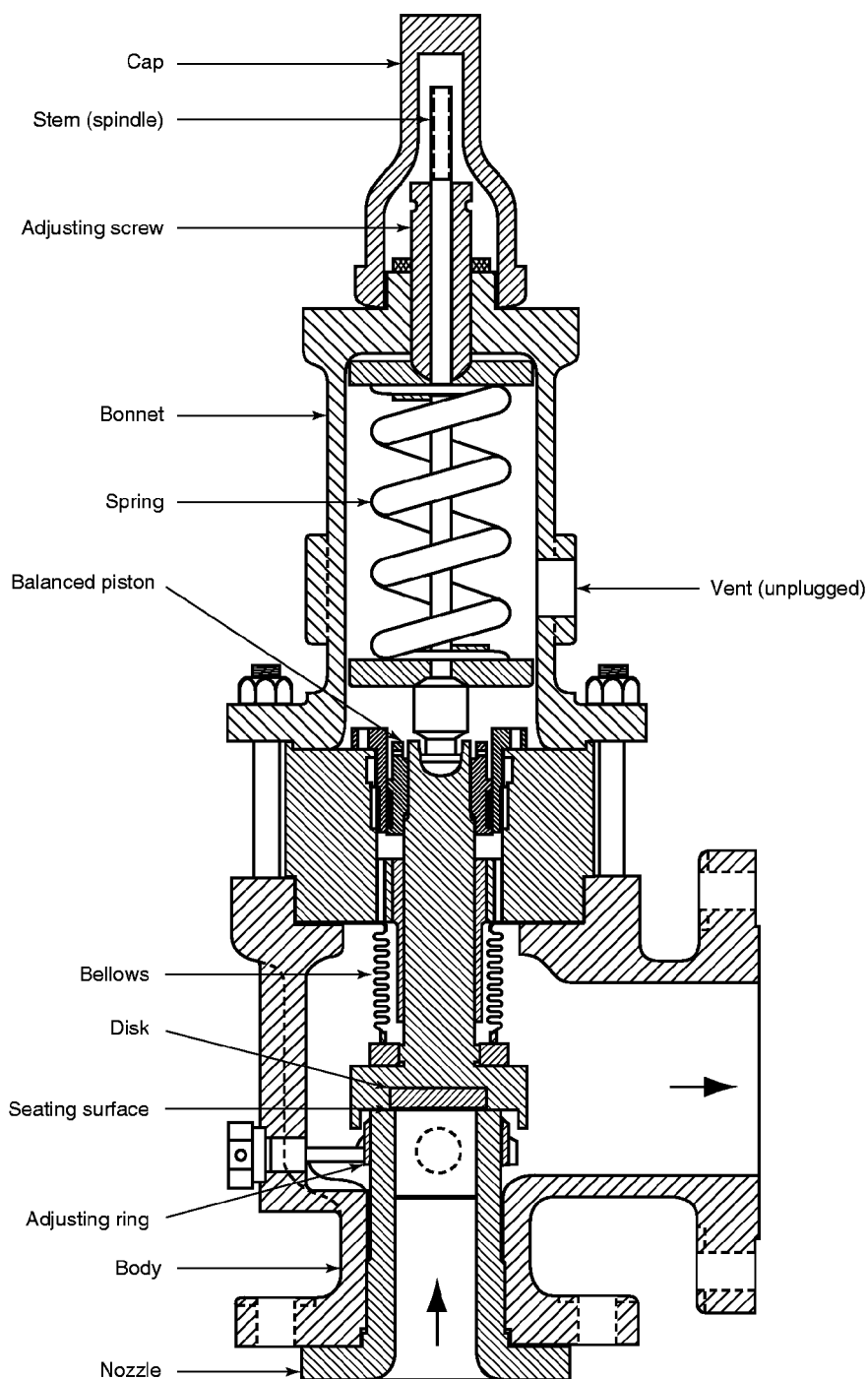

Figure 4—Balanced-Bellows Pressure Relief Valve with an Auxiliary Balanced Piston

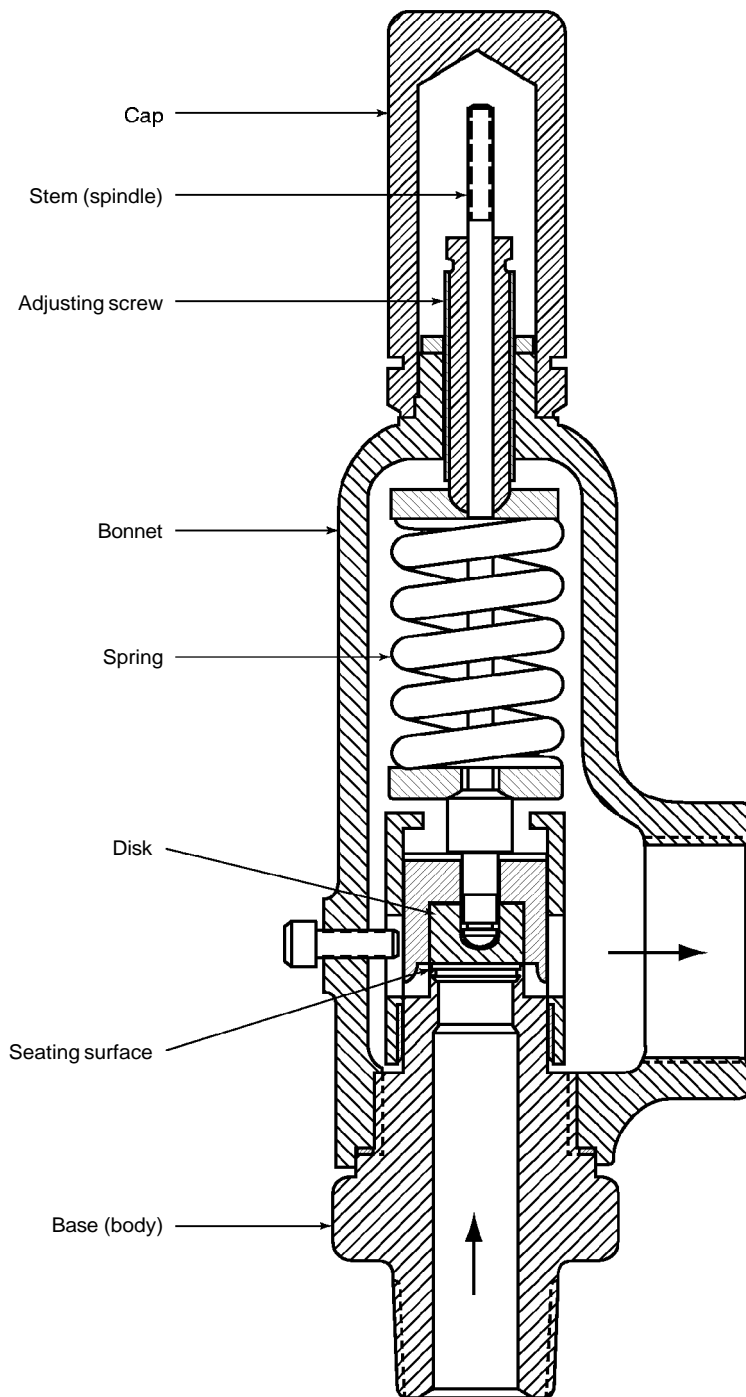

Figure 5—Conventional Pressure Relief Valve with Threaded Connections

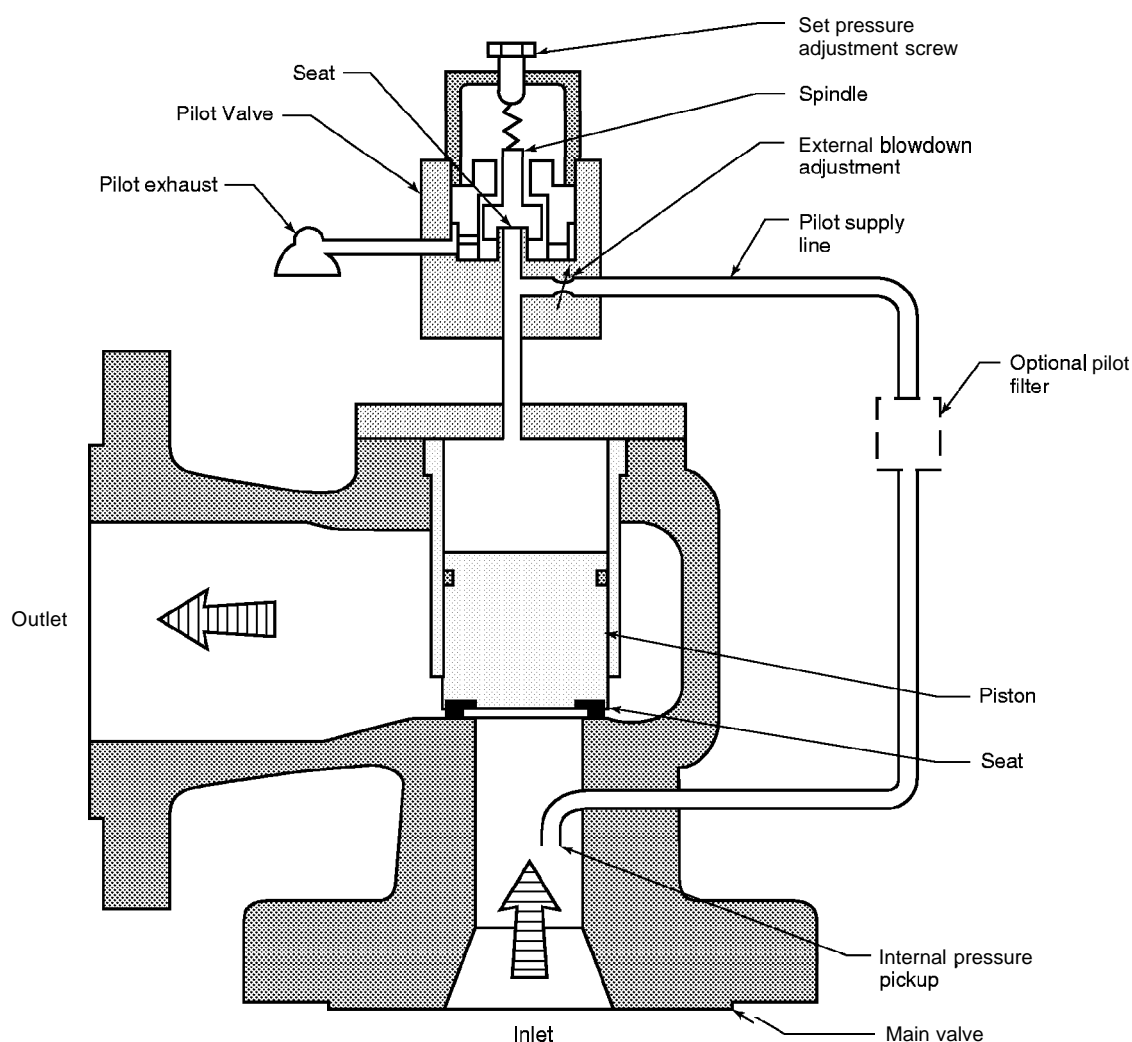

Figure 6—Pop-Action Pilot-Operated Valve (Flowing-Type)

2.2.1.2.11 In some applications, the valve may be required to relieve a liquid or a gas depending on the condition causing the overpressure (heat exchanger tube rupture, for example). In this application, a valve designed for liquid service or one designed for liquid and gas service is recommended.

2.2.1.3 Balanced Pressure Relief Valves

2.2.1.3.1 A balanced pressure relief valve is a spring-loaded pressure relief valve which incorporates a bellows or other means of balancing the valve disc to minimize the effects of back pressure on the performance characteristics of the valve (see Figures 3 and 4).

2.2.1.3.2 When a superimposed back pressure is applied to the outlet of a spring-loaded pressure relief valve, a pressure

force is applied to the valve disc which is additive to the spring force. This added force increases the pressure at which an unbalanced pressure relief valve will open. If the superimposed back pressure is variable then the pressure at which the valve will open will vary (see Figure 22). In a balanced-bellows pressure relief valve, a bellows is attached to the disc holder with a pressure area, A_B , approximately equal to the seating area of the disc, A_N (see Figure 23). This isolates an area on the disc, approximately equal to the disc seat area, from the back pressure. With the addition of a bellows, therefore, the set pressure of the pressure relief valve will remain constant in spite of variations in back pressure. Note that the internal area of the bellows in a balanced-bellows spring-loaded pressure relief valve is referenced to atmospheric pressure in the valve bonnet. It is important to remember that the

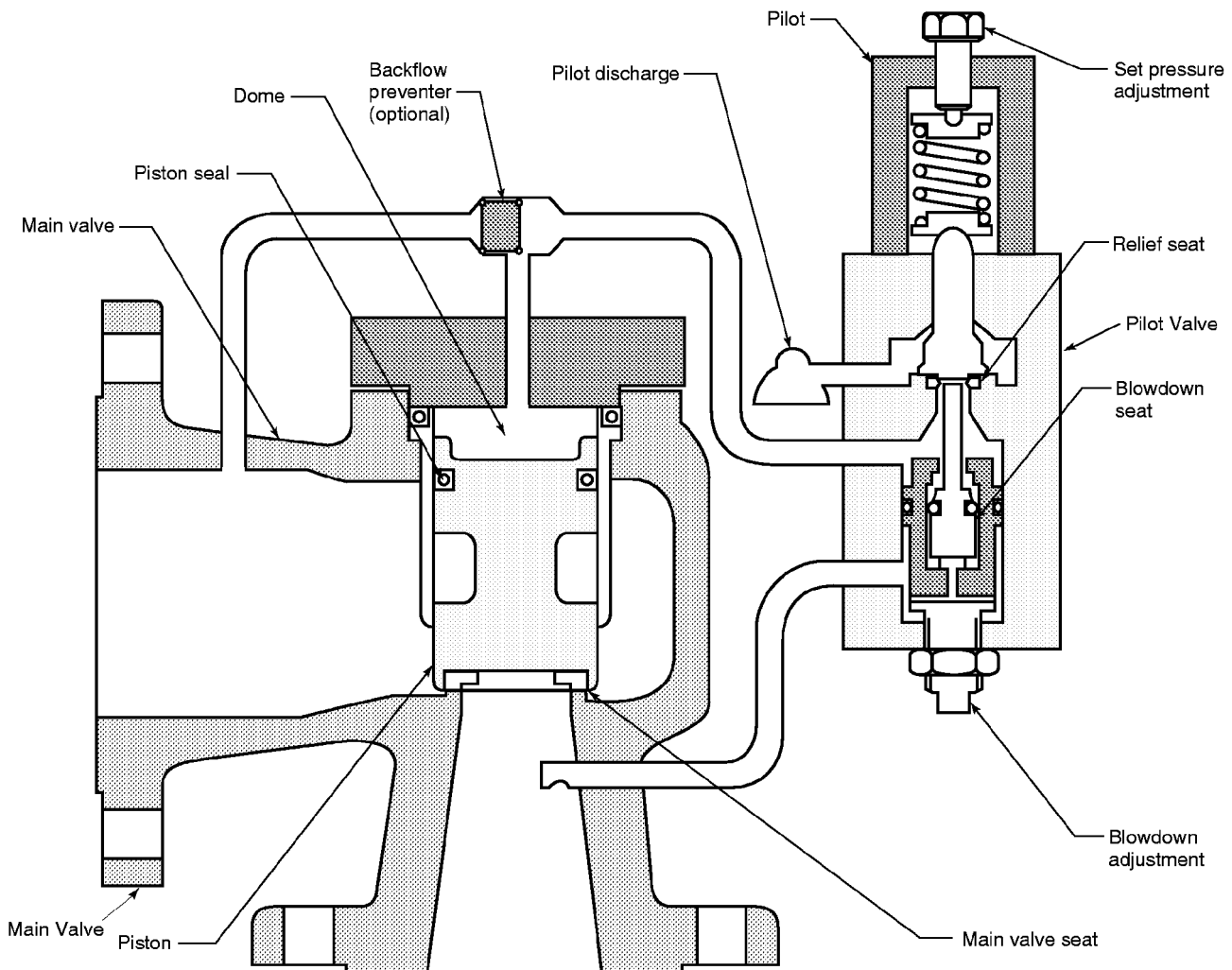

Figure 7—Pop-Action Pilot-Operated Valve (Nonflowing-Type)

bonnet of a balanced pressure relief valve must be vented to the atmosphere at all times for the bellows to perform properly. If the valve is located where atmospheric venting would present a hazard or is not permitted by environmental regulations, the vent should be piped to a safe location that is free of back pressure that may affect the pressure relief valve set pressure.

2.2.1.3.3 Other means of balancing a spring-loaded pressure relief valve such as a sealed piston are used in some valve designs. These designs perform in a manner similar to the balanced bellows design.

2.2.1.3.4 When the superimposed back pressure is constant, the spring-load can be reduced to compensate for the effect of back pressure on set pressure, and a balanced valve is not required. There are cases where superimposed back

pressure is not always constant and such cases must be evaluated carefully.

2.2.1.3.5 Balanced pressure relief valves should be considered where the built-up back pressure (back pressure caused by flow through the downstream piping after the relief valve lifts) is too high for a conventional pressure relief (see 3.3.3.1). A detailed discussion of back pressure and its effects on pressure relief valve performance and flow capacity can be found in 3.3.

2.2.1.3.6 Balanced pressure relief valves may also be used as a means to isolate the guide, spring, bonnet and other top works parts within the valve from the relieving fluid. This may be important if there is concern that the fluid will cause corrosive damage to these parts.

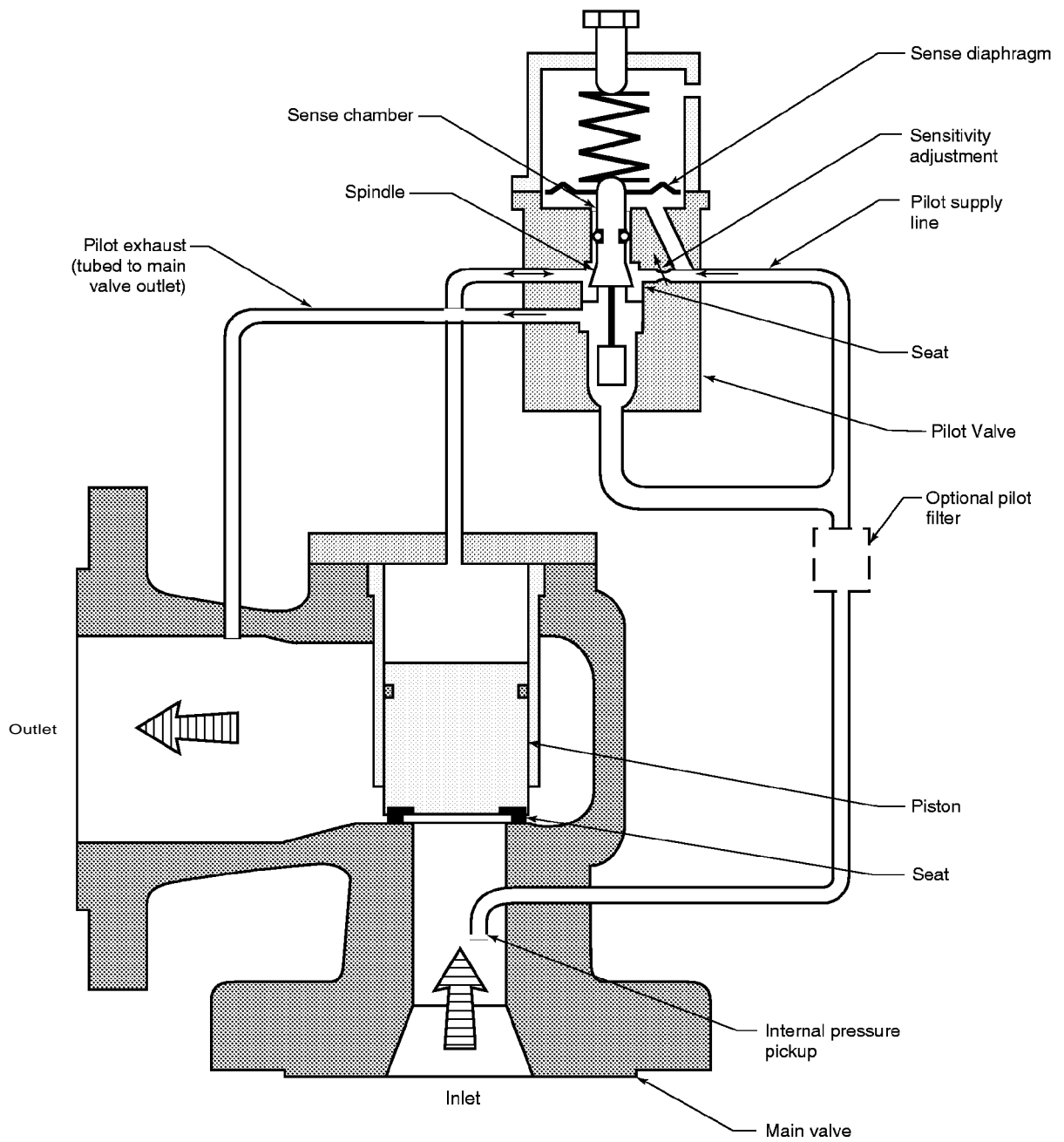

Figure 8—Modulating Pilot-Operated Valve (Flowing-Type)

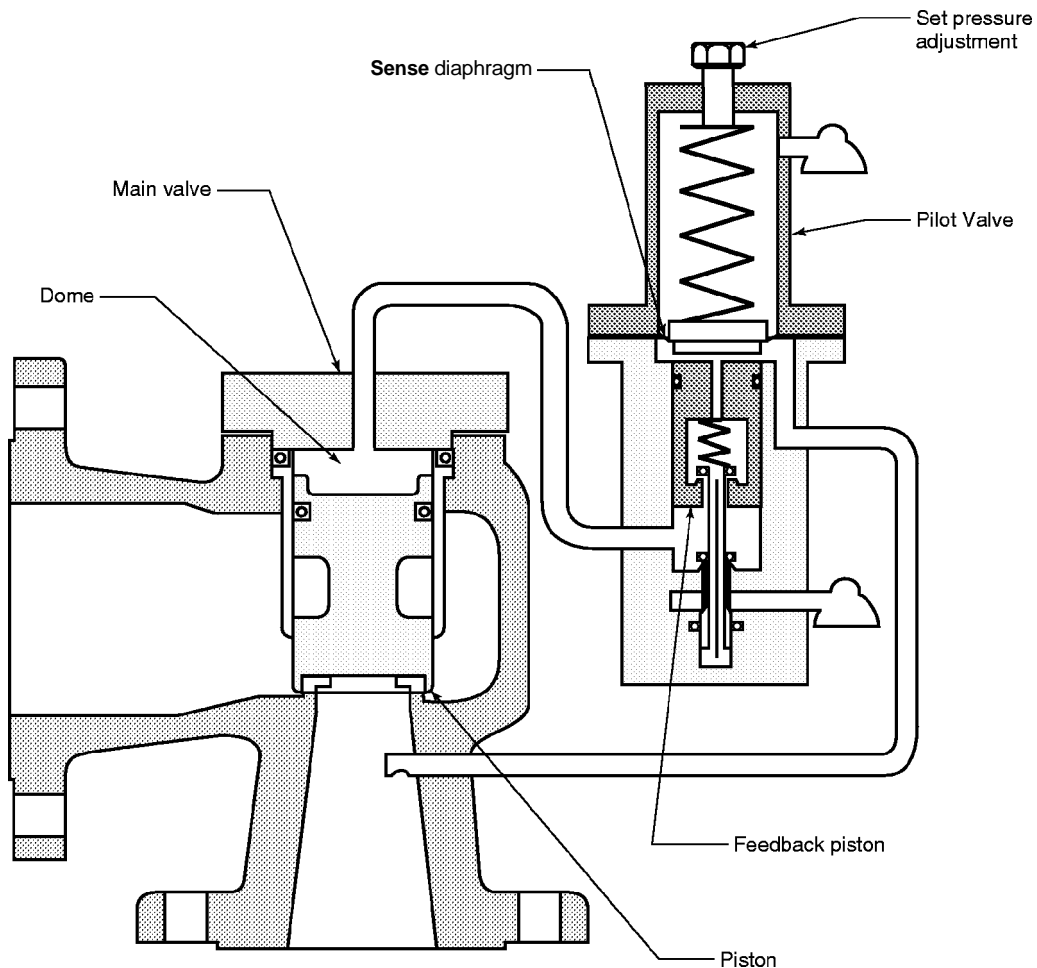

Figure 9—Pilot-Operated Relief Valve with a Nonflowing Modulating Pilot Valve

2.2.2 Pilot-Operated Pressure Relief Valves

2.2.2.1 A pilot-operated pressure relief valve consists of the main valve, which normally encloses a floating unbalanced piston assembly, and an external pilot (see Figures 6 through 10). The piston is designed to have a larger area on the top than on the bottom. Up to the set pressure, the top and bottom areas are exposed to the same inlet operating pressure. Because of the larger area on the top of the piston, the net force holds the piston tightly against the main valve nozzle. As the operating pressure increases, the net seating force increases and tends to make the valve tighter. This feature allows most pilot-operated valves to be used where the maximum expected operating pressure is higher than the percentage shown in Figure 1. At the set pressure, the pilot vents the pressure from the top of the piston; the resulting net force is

now upward causing the piston to lift, and process flow is established through the main valve. After the overpressure incident, the pilot will close the vent from the top of the piston, thereby re-establishing pressure, and the net force will cause the piston to reseat.

2.2.2.2 The main valve of the pilot-operated pressure relief valve can use a diaphragm in lieu of a piston to provide the unbalanced moving component of the valve. A disc, which normally closes the main valve inlet, is integral with a flexible diaphragm (see Figure 10). The external pilot serves the same function to sense process pressure, vent the top of the diaphragm at set pressure, and reload the diaphragm once the process pressure is reduced. As with the piston valve, the seating force increases proportionally with the operating pressure because of the differential exposed area of the diaphragm.

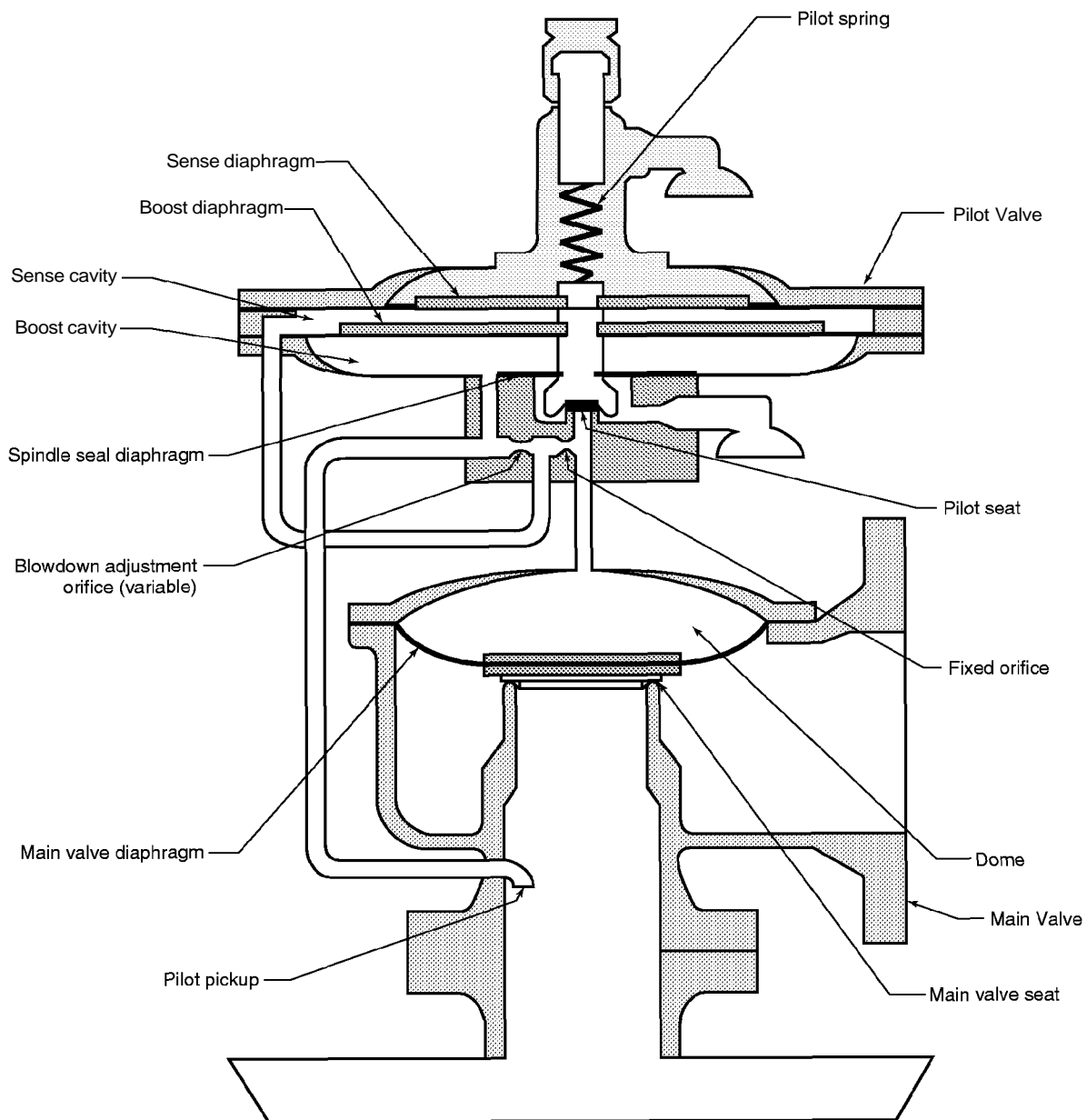

Figure 10—Low-Pressure Pilot-Operated Valve (Diaphragm-Type)

2.2.2.3 The lift of the main valve piston or diaphragm, unlike a conventional or balanced spring loaded valve, is not affected by built-up back pressure. This allows for even higher pressures in the relief discharge manifolds.

2.2.2.4 The pilot vent can be either directly exhausted to atmosphere or to the main valve outlet depending upon the pilot's design and user's requirement. Only a balanced-type of pilot, where set pressure is unaffected by back pressure, should be installed with its exhaust connected to a location with varying pressure (such as to the main valve outlet).

Slight variations in back pressure may be acceptable for unbalanced pilots (see 3.3.3.1).

2.2.2.5 A backflow preventer is required when the possibility exists of developing a pressure on the discharge side of the valve that exceeds the inlet pressure of the valve. The higher discharge pressure can cause sufficient upward force on the diaphragm or piston to open the valve and cause flow reversal. The backflow preventer allows the discharge pressure to provide a net downward force on the diaphragm or piston to keep the valve closed (see Figure 7). The proper operation of

the backflow preventer is critical to further insuring no flow reversal occurs in the valve. The selection of the material and seals in the backflow preventer should be consistent with the pilot-operated relief valve.

2.2.2.6 The pilot that operates the main valve can be either a pop-action or modulating-action pilot. The pop-action pilot, as shown in Figure 24, causes the main valve to lift fully at set pressure without overpressure. The modulating pilot, as shown in Figure 25, opens the main valve only enough to satisfy the required relieving capacity.

2.2.2.7 The pilots may be either a flowing or nonflowing type. The flowing type allows process fluid to continuously flow through the pilot when the main valve is open; the nonflowing type does not. The nonflowing pilot-type is generally recommended for most services to reduce the possibility of hydrate formation (icing) or solids in the lading fluid affecting the pilot's performance.

2.2.2.8 Pilot-operated pressure relief valves are available for use in liquid and vapor services. Operating characteristics of some pilot-operated pressure relief valves are unaffected by the state of fluid (liquid or gas) and these types are recommended for two-phase flow applications.

2.2.2.9 Similar to soft seated spring-loaded valves, most main valves and their pilots contain nonmetallic components and process temperature and fluid compatibility can limit their use. In addition, as with all pressure relief devices, fluid characteristics such as susceptibility to polymerization or fouling, viscosity, the presence of solids, and corrosiveness should be considered. The manufacturer should be consulted to ensure that the proposed application is compatible with available valves.

2.3 RUPTURE DISK DEVICES

2.3.1 General

2.3.1.1 Rupture disk devices are non-reclosing pressure relief devices used to protect vessels, piping and other pressure containing components from excessive pressure and/or vacuum. Rupture disks are used in single and multiple relief device installations. They are also used as redundant pressure relief devices.

2.3.1.2 With no moving parts, rupture disks are simple, reliable and faster acting than other pressure relief devices. Rupture disks react quickly enough to relieve some types of pressure spikes. Because of their light weight, rupture disks can be made from high alloy and corrosion-resistant materials that are not practical in pressure relief valves.

2.3.1.3 Rupture disks can be specified for systems with vapor (gas) or liquid pressure relief requirements. Also, rupture disk designs are available for highly viscous fluids. The use of rupture disk devices in liquid service should be

carefully evaluated to ensure that the design of the disk is suitable for liquid service. The user should consult the manufacturer for information regarding liquid service applications.

2.3.1.4 The rupture disk is also a temperature sensitive device. Burst pressures can vary significantly with the temperature of the rupture disk device. This temperature may be different from the normal fluid operating temperature. As the temperature at the disk increases, the burst pressure usually decreases. Since the effect of temperature depends on the rupture disk design and material, the manufacturer should be consulted for specific applications. For these reasons, the rupture disk must be specified at the pressure and temperature the disk is expected to burst.

2.3.1.5 Care must be taken during installation to avoid damaging the disk and to ensure that the disk and holder are properly oriented relative to the flow. A damaged or improperly oriented disk may burst considerably higher than its marked burst pressure, depending on the style of the disk. Contact the manufacturer for information about the effects of damage or improper orientation for a specific style of disk.

2.3.1.6 Care must also be taken to follow the manufacturer's bolt torque and tightening procedures during installation. Improper torque can also affect the disk's burst pressure.

2.3.2 Application of Rupture Disks

2.3.2.1 Single, Multiple, and Fire Applications

Rupture disks can be used in any application requiring overpressure protection where a non-reclosing device is suitable. This includes single, multiple, and fire applications as specified in UG-134 of the ASME Code. Figure 26 provides the pressure level relationships between rupture disks and the protected equipment per the ASME Code, Section VIII.

2.3.2.2 Rupture Disk Device at the Inlet of a Pressure Relief Valve

2.3.2.2.1 The ASME Code, Section VIII, Division 1 also allows for the use of rupture disks in combination with pressure relief valves (see Figure 17). Rupture disks are used upstream of pressure relief valves to seal the system to meet emissions standards, to provide corrosion protection for the valve, and to reduce valve maintenance.

2.3.2.2.2 When a rupture disk device is installed at the inlet of a pressure relief valve, the devices are considered to be close coupled, and the specified burst pressure and set pressure should be the same nominal value. When installed in liquid service it is especially important for the disk and valve to be close coupled to reduce shock loading on the valve.

2.3.2.2.3 The space between the rupture disk and the pressure relief valve shall have a free vent, pressure gauge,

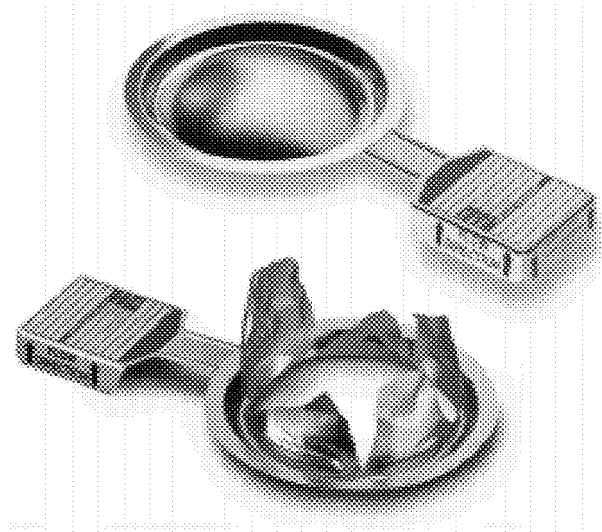

CORRECT INSTALLATION

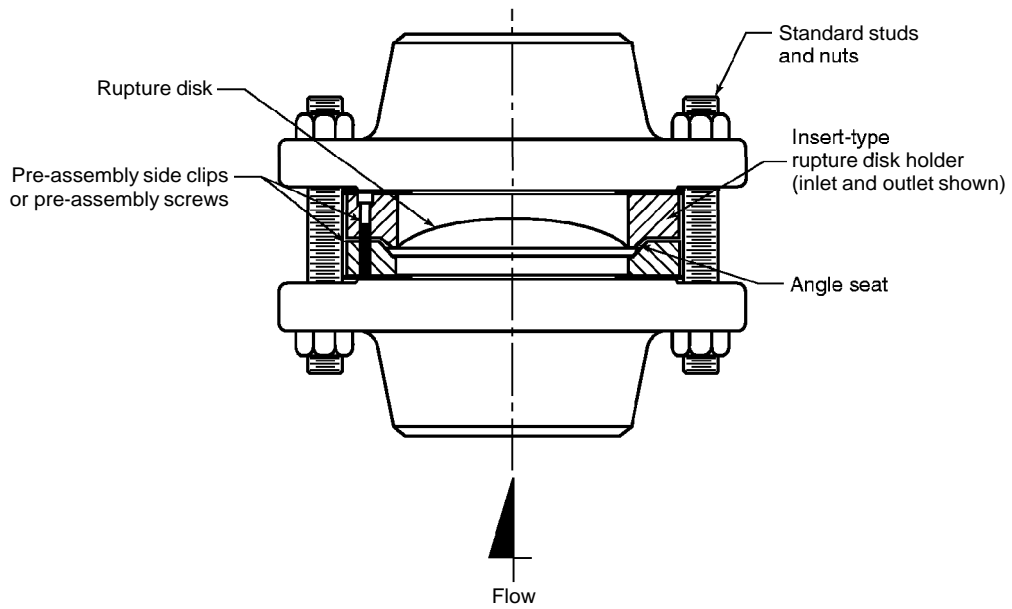

Figure 11 — Forward-Acting Solid Metal Rupture Disk

trycock, or suitable telltale indicator as required in UG-127 of Section VIII, Division I, of the ASME Code. A nonvented space with a pressure gauge without alarms or other devices, is not recommended as a suitable telltale indicator. Users are warned that a rupture disk will not burst in tolerance if back pressure builds up in a nonvented space between the disk and the pressure relief valve, which will occur should leakage develop in the rupture disk due to corrosion or other cause.

2.3.2.3 Rupture Disk Device at the Outlet of a Pressure Relief Valve

A rupture disk device may be installed on the outlet of a pressure relief valve to protect the valve from atmospheric or downstream fluids. Consideration shall be given to the valve design so that it will open at its proper pressure setting regardless of any back pressure that may accumulate between the valve and rupture disk. See UG-127 of the ASME Code for other requirements and considerations.

2.3.2.4 Highly Corrosive Applications

In highly corrosive applications, two rupture disks are often used together. A double disk assembly consists of two rupture disks mounted in a special holder with a vapor space between them. If the first disk develops a leak due to corrosion the second disk will contain the fluid. The vapor space between the disks should have a free vent, pressure gauge, trycock or suitable telltale indicator for monitoring of pressure build-up. This gives the user an indication that replacement of the rupture disk is required.

2.3.2.5 Highly Viscous Applications

Rupture disk designs are available for processes with high viscosity fluid, including nonabrasive slurries, where fluid flow is directed across the rupture disk inlet to prevent product build-up which may otherwise adversely affect rupture disk performance. The disk manufacturer should be consulted for details in these applications.

2.3.3 Types of Rupture Disks

There are 3 major rupture disk types:

- a. Forward-acting, tension loaded.
- b. Reverse-acting, compression loaded.
- c. Graphite, shear loaded.

2.3.3.1 Forward-Acting Solid Metal Rupture Disks

A forward-acting rupture disk is a formed (domed), solid metal disk designed to burst at a rated pressure applied to the concave side (see Figure 11). This rupture disk typically has an angular seat design and provides a satisfactory ser-

vice life when operating pressures are up to 70% of the marked burst pressure of the disk (70% operating ratio). Consult the manufacturer for the actual recommended operating ratio for the specific disk under consideration. If vacuum or back pressure conditions are present, the disk can be furnished with a support to prevent reverse flexing. These disks have a random opening pattern and are considered fragmenting designs that are not suitable for installation upstream of a pressure relief valve.

2.3.3.2 Forward-Acting Scored Rupture Disks

The scored forward-acting rupture disk is a formed (domed) disk designed to burst along scored lines at a rated pressure applied to the concave side (see Figure 12). Some designs provide satisfactory service life when operating pressures are up to 85% – 90% of the marked burst pressure of the disk (85% – 90% operating ratio). Consult the manufacturer for the actual recommended operating ratio for the specific disk under consideration. Most designs withstand vacuum conditions without a vacuum support. If back pressure conditions are present, the disk can be furnished with a support to prevent reverse flexing. Because the score lines control the opening pattern, this type of disk can be manufactured to be nonfragmenting and acceptable for installation upstream of a pressure relief valve. The scored, forward-acting rupture disk is manufactured from thicker material than nonscored designs with the same burst pressure, and provides additional resistance to mechanical damage.

2.3.3.3 Forward-Acting Composite Rupture Disks

2.3.3.3.1 A forward-acting composite rupture disk is a flat or domed multipiece construction disk (see Figure 13). The domed composite rupture disk is designed to burst at a rated pressure applied to the concave side. The flat composite rupture disk may be designed to burst at a rated pressure in either or both directions. Some designs are nonfragmenting and acceptable for use upstream of a pressure relief valve.

2.3.3.3.2 The domed composite rupture disk is available in flat seat or angular seat design. The burst pressure is controlled by the combination of slits and tabs in the top section and a metallic or nonmetallic seal member under the top section. Composite rupture disks are generally available in burst pressures lower than those of forward acting, nonscored rupture disks. Composite rupture disks may offer a longer service life as a result of the corrosion resistant properties of the seal material selected.

2.3.3.3.3 The slits and tabs in the top section provide a predetermined opening pattern for the rupture disk. If vacuum or back pressure conditions are present, composite disks can be furnished with a support to prevent reverse flexing (see Figure 13). A domed, composite rupture disk generally

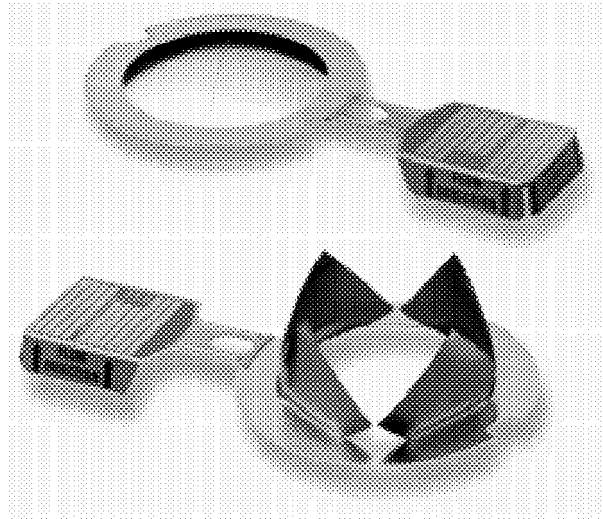

CORRECT INSTALLATION

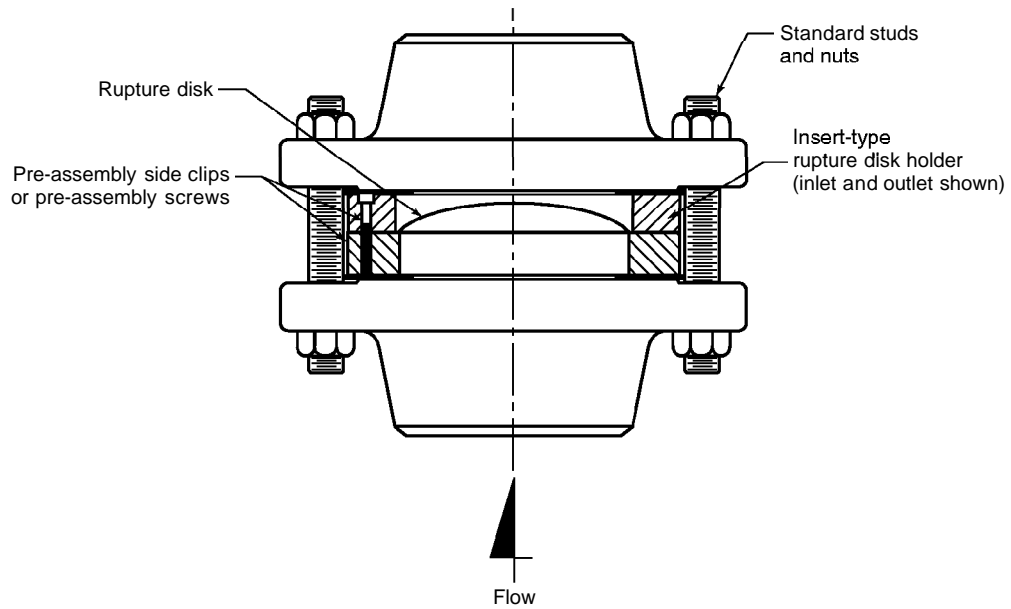

Figure 12—Forward-Acting Scored Rupture Disk

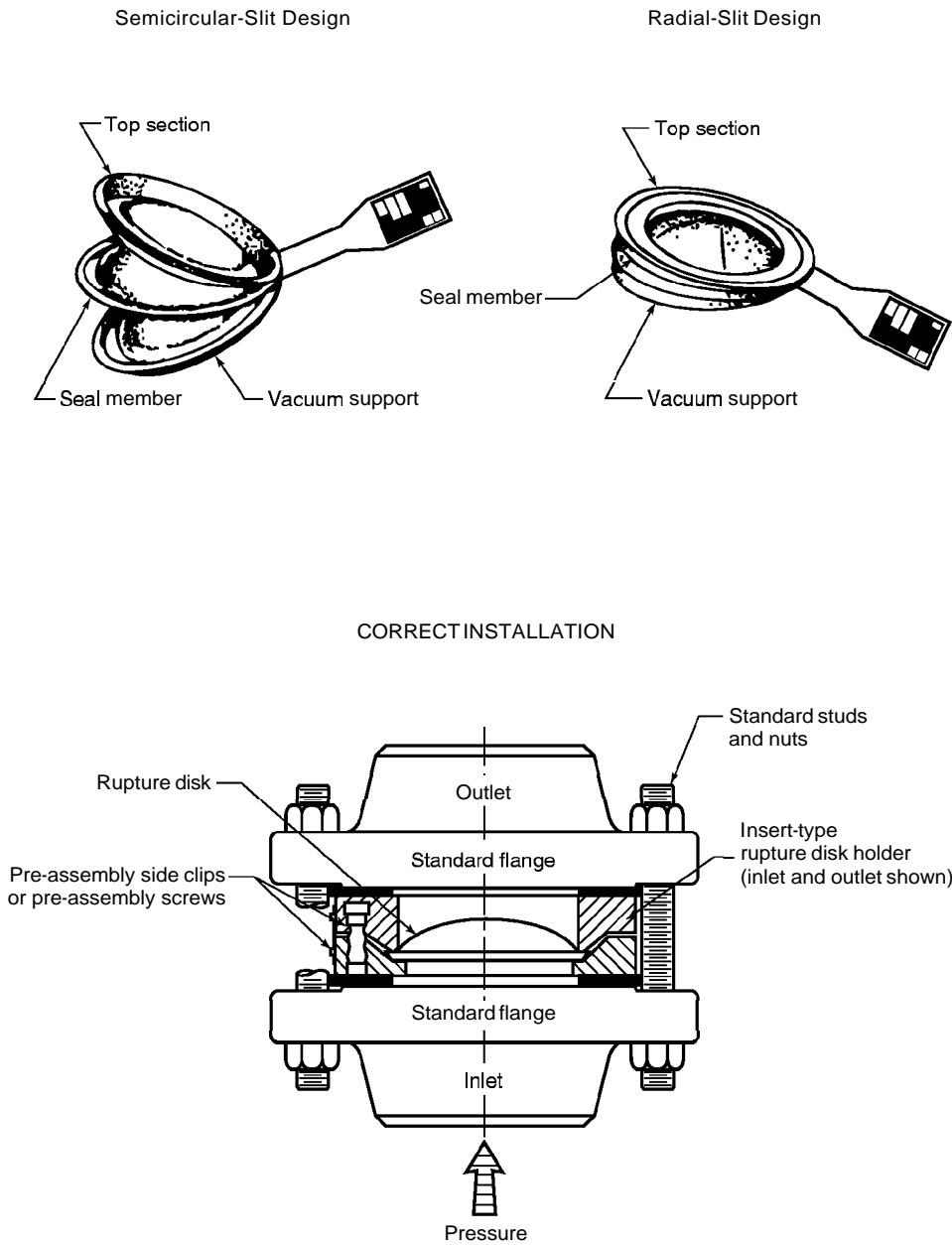

Figure 13—Forward-Acting Composite Rupture Disk

provides satisfactory service life when the operating pressure is 80% or less of the marked burst pressure (80% operating ratio). Consult the manufacturer for the actual recommended operating ratio for the specific disk under consideration.

2.3.3.3.4 A flat composite rupture disk is available for the protection of low pressure vessels or the isolation of equipment such as exhaust headers or the outlet side of a pressure relief valve. This disk usually comes complete with gaskets and is designed to be installed between companion flanges rather than within a specific rupture disk holder. Flat composite rupture disks generally provide satisfactory service life when operating pressures are 50% or less of the marked burst pressure (50% operating ratio). Consult the manufacturer for the actual recommended operating ratio for the specific disk under consideration.

2.3.3.4 Reverse-Acting Rupture Disks

2.3.3.4.1 A reverse-acting rupture disk typically is a formed (domed) solid metal disk designed to "reverse" and burst at a rated pressure applied on the convex side. Reverse-acting rupture disks are designed to open by such methods as shear, knife blades, knife rings, or scored lines (see Figures 14 and 15).

2.3.3.4.2 Reverse-acting rupture disks may be manufactured as nonfragmenting and suitable for installation upstream of pressure relief valves. These disks provide satisfactory service life when operating pressures are 90% or less of marked burst pressure (90% operating ratio). Consult the manufacturer for the actual recommended operating ratio for the specific disk under consideration. Because a reverse-acting rupture disk is operated with pressure applied on the convex side, thicker disk materials may be used, thereby lessening the effects of corrosion, eliminating the need for vacuum support, and providing longer service life under pressure/vacuum cycling conditions and pressure fluctuations.

2.3.3.4.3 Knife blades installed in holders should be constructed of corrosion-resistant material and should be inspected periodically to insure sufficient sharpness to open the disk. Dull or damaged knife blades may prevent proper opening of the disk.

2.3.3.5 Graphite Rupture Disks

2.3.3.5.1 Graphite rupture disks are typically machined from a bar of fine graphite that has been impregnated with a binding compound (see Figure 16). The disk operates on a pressure differential across the center diaphragm or web portion of the disk. Graphite rupture disks provide a satisfactory service life when operating pressures are up to 80% of the marked burst pressure (80% operating ratio) and can be used

in both liquid and vapor service. Consult the manufacturer for the actual recommended operating ratio for the specific disk under consideration.

2.3.3.5.2 If vacuum or back pressure conditions are present, the disk can be furnished with a support to prevent reverse flexing. These disks have a random opening pattern and are considered fragmenting designs that are not suitable for installation upstream of a pressure relief valve. A metallic ring called armoring is often added to the outside diameter of the disk to help support uneven piping loads and minimize the potential for cracking of the outer graphite ring and blow-out of process fluid.

2.3.4 Rupture Disk Holders

Rupture disk holders are used to clamp the rupture disk in place and effect a leak-tight, metal-to-metal seal. The seating area of the holders is typically unique to specific manufacturers and styles of rupture disks. Rupture disk holders are available in a variety of configurations including full bolting, weldneck, threaded, etc. The most common configuration is the insert type which fits between standard pipe flanges, and the outside diameter of the holder fits inside the flange studs. Rupture disk holders are available in a variety of materials and coatings.

2.3.5 Rupture Disk Accessories

A variety of accessories are available for use with rupture disks in various applications. The following provides a brief description of some of these components and their application.

- a. Rupture Indicators and Sensors—These devices typically provide an electrical or mechanical signal which can indicate the opening and/or leakage of a rupture disk or pressure relief valve.
- b. Alarm Monitors—Alarm monitors are available to monitor rupture disk indicators or sensors. Alarm monitors are available with intrinsically safe circuits.
- c. Heat Shields—Heat shields are generally installed upstream of the rupture disk in high temperature processes to reduce the temperature at the rupture disk.
- d. Baffle Plates—When venting to atmosphere, baffle plates can be used to deflect process discharge away from personnel and equipment.

2.3.6 Rupture Disk Selection and Specification

Rupture disk selection is based on the operating parameters of the system in which it is installed. These parameters should be specified by the Purchaser when purchasing rupture disks. These parameters include, but are not limited to:

- a. MAWP of vessel or piping.
- b. Fluid state (vapor, liquid, or multiphase).

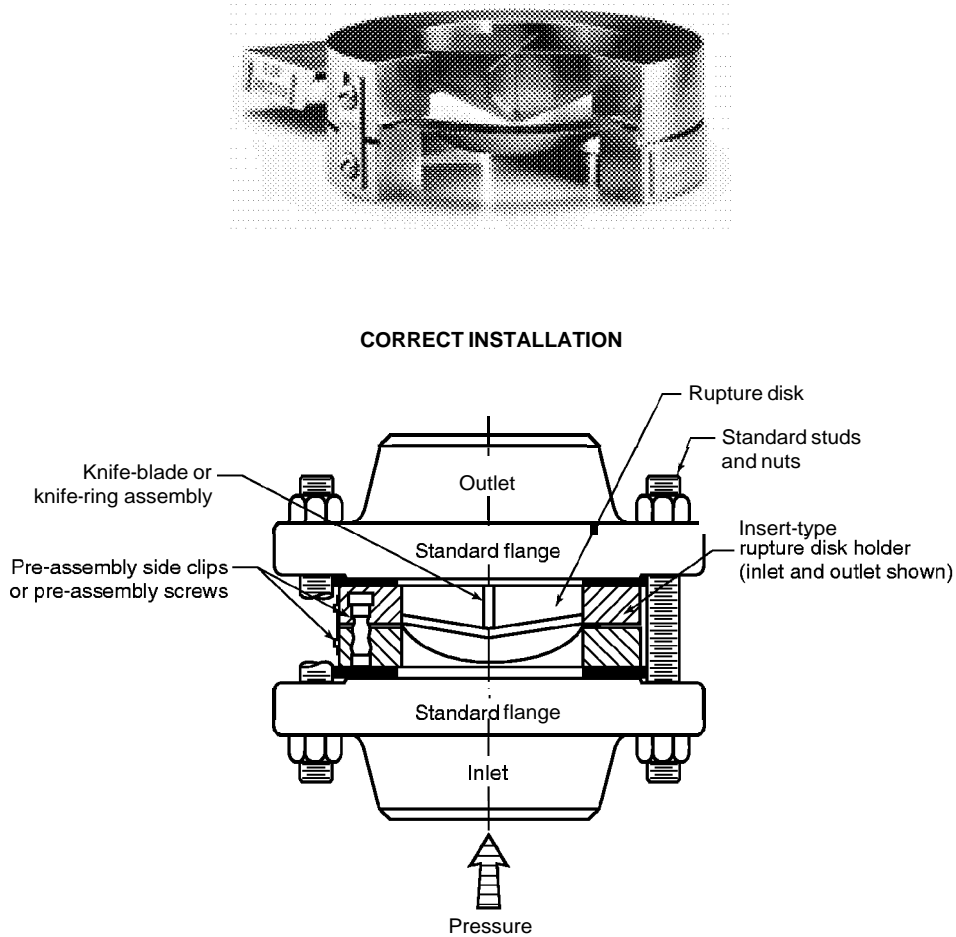

Figure 14--Reverse-Acting Rupture Disk with Knife Blades

- c. Range of operating pressures and operating temperature.
- d. Cyclic or pulsating service.
- e. Required relieving capacity.
- f. Corrosiveness of upstream and downstream environment.
- g. Vacuum or back pressure conditions.
- h. Location upstream or downstream of a pressure relief valve.
- i. Single or multiple devices.

The following rupture disk parameters are selected or determined based on the above system operating parameters:

- a. Burst pressure and temperature (see Figure 26).
- b. Operating ratio, manufacturing range and burst tolerance (see Figures 28A, 28B, and 28C).
- c. Disk type, material and construction.
- d. Disk and holder size (based on required flow per 3.11).

2.3.6.1 Rupture Disk Selection

2.3.6.1.1 Rupture disk types and basic performance characteristics are described in 2.3.3 and may be used as a basis for selection. The relationship between system pressures and the operating characteristics of a rupture disk device are shown in Figure 26. Since the marked burst pressure of a rupture disk can be anywhere within its manufacturing range, the user is cautioned to make sure that the upper limit of the manufacturing range does not exceed the MAWP of the equipment being protected. As shown in Figure 27, when the disk has a positive manufacturing range, the marked burst pressure of the disk can actually be greater than the specified pressure.

2.3.6.1.2 The maximum pressure at which a rupture disk may be marked to burst is the upper limit of its manufacturing range. The minimum pressure at which a rupture disk may be marked to burst is the lower limit of its manufacturing range. Figures 28A, 28B, and 28C provide graphical examples of



CORRECT INSTALLATION

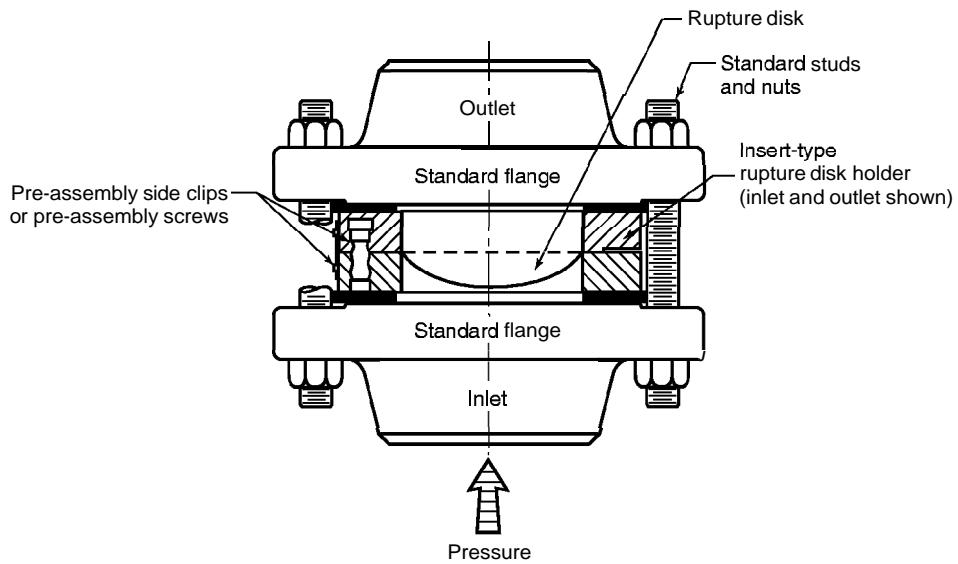

Figure 15—Reverse-Acting Scored Rupture Disk

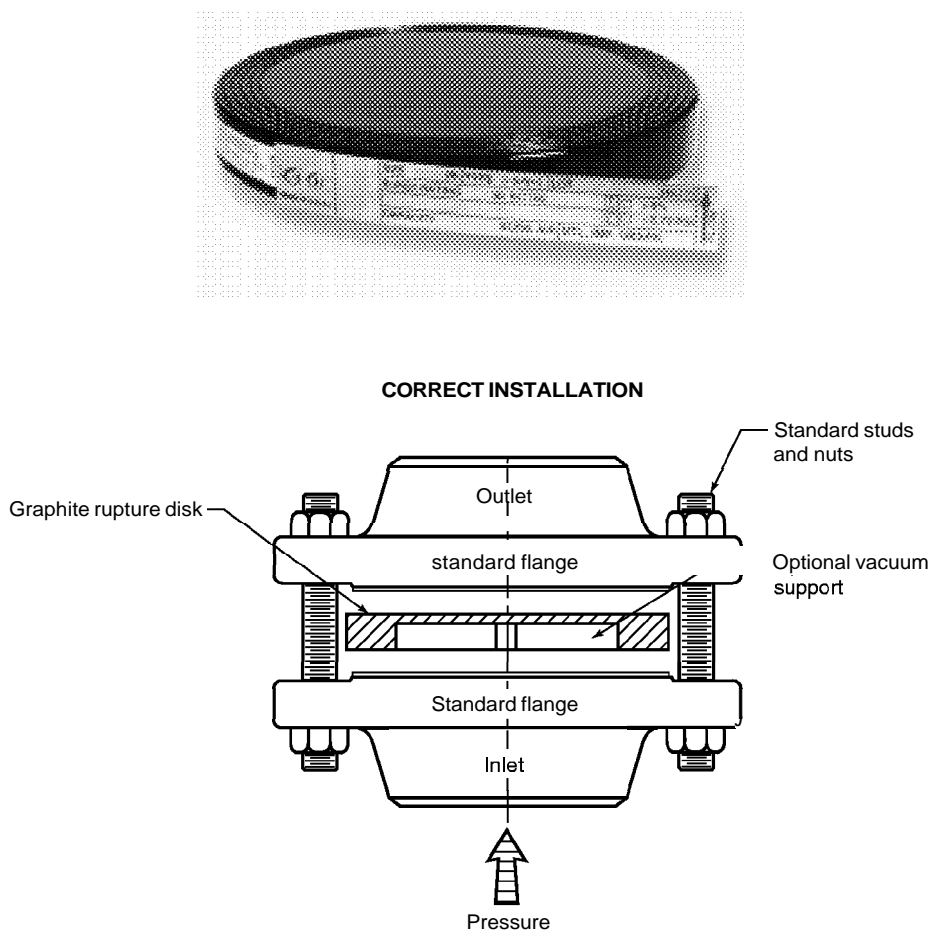

Figure 16—Graphite Rupture Disk

common relationships between burst pressure, manufacturing range, burst tolerance, and operating pressure.

2.3.6.1.3 Rupture disk selection is an iterative and sometimes complex process. The procedure given below should be used for rupture disk selection where there is no superimposed back pressure. Consult the manufacturer for assistance if needed.

1. Select the upper limit of the manufacturing range. This is typically based on the MAWP of the protected equipment as determined by the ASME Code or process requirements. In some applications, such as in multiple or supplemental device installation (see 3.5.2), the upper limit of the manufacturing range may exceed the MAW of the protected equipment.
2. Determine the specified burst pressure by subtracting the positive portion of the manufacturing range, as listed in the manufacturer's catalog, from the upper limit of the manufacturing range.

3. Determine the lower limit of the manufacturing range by subtracting the negative portion of the manufacturing range, as listed in the manufacturer's catalog, from the specified burst pressure.

4. Determine the operating ratio by dividing the maximum operating pressure by the lower limit of the manufacturing range.

Note: When calculating the operating ratio for disks with specified burst pressures less than 40 psig, subtract 2 psi from the lower limit of the manufacturing range prior to calculating the operating ratio.

5. Select a rupture disk based on the specified burst pressure and the manufacturing range, and compare the operating ratio with the manufacturer's maximum recommended operating ratio as listed in the product catalog. If the operating ratio exceeds the manufacturer's maximum recommended operating ratio, select a smaller manufacturing range, if available, for that disk style or change disk style and repeat steps 2 through 5.

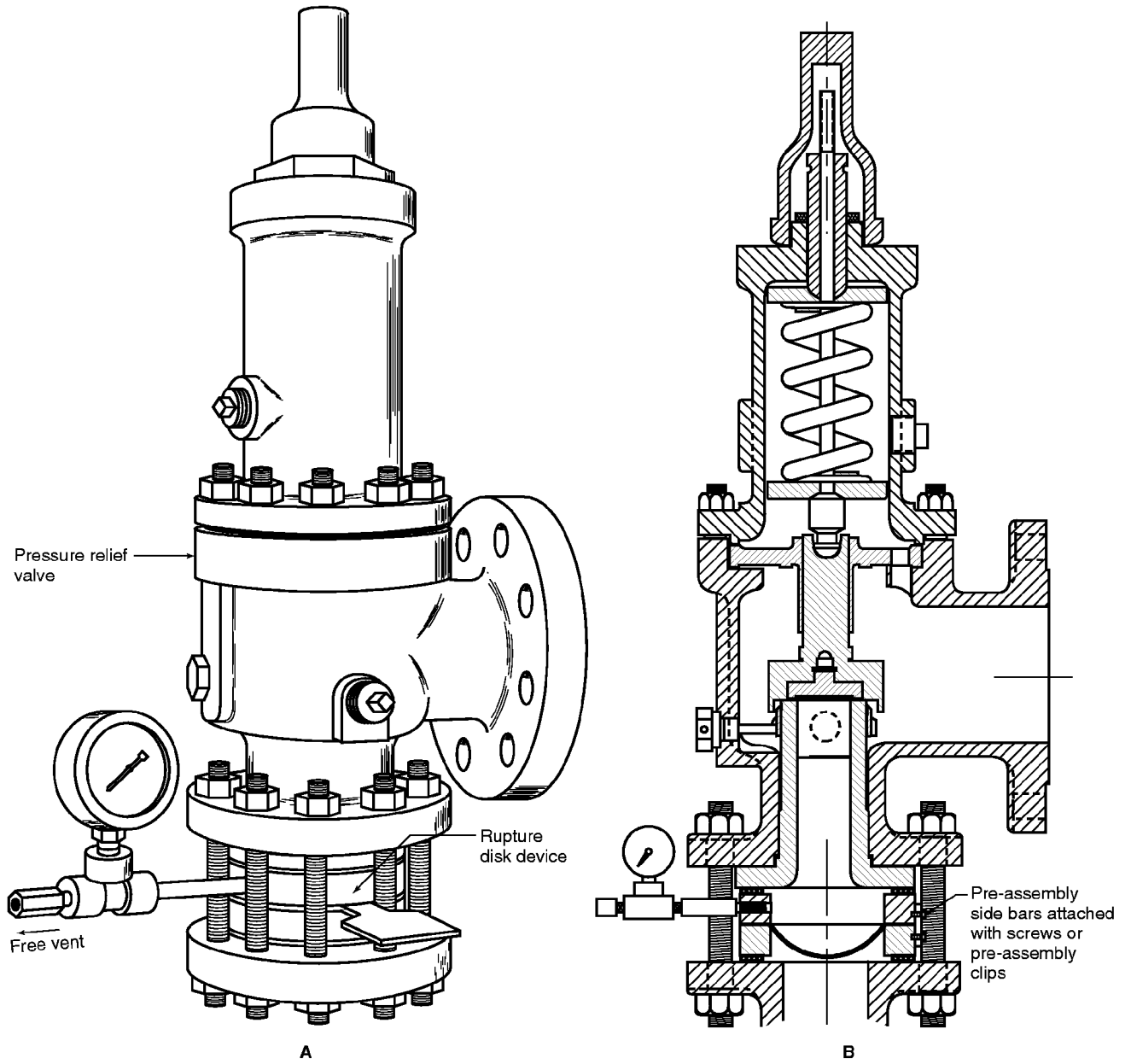

Figure 17—Rupture Disk Device in Combination with a Pressure Relief Valve

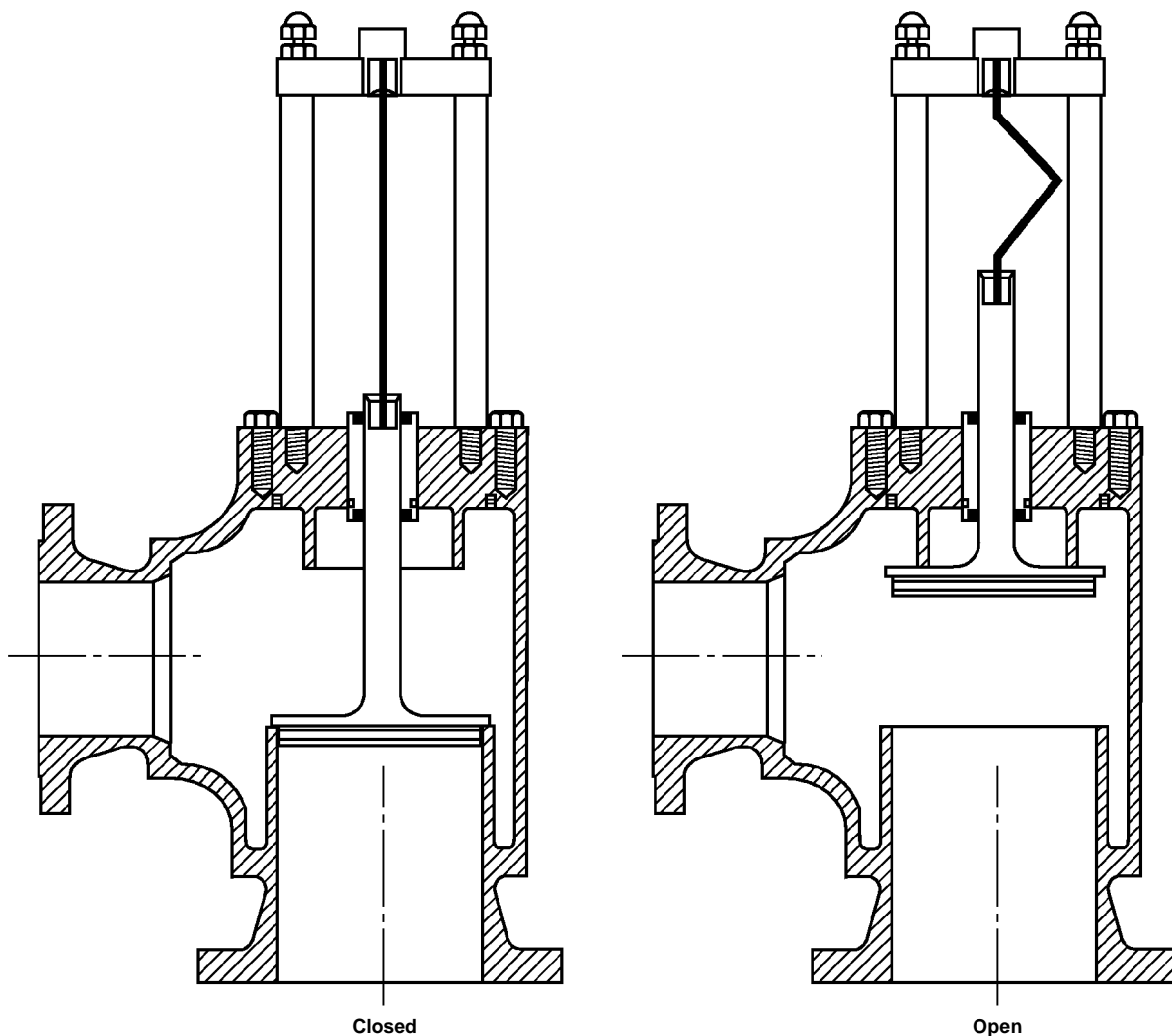

Figure 18—Buckling Pin Valve

2.3.6.1.4 Superimposed back pressure significantly complicates the design and selection process of the rupture disk device. Figure 29 provides an example of a rupture disk with superimposed back pressure. The impact of the superimposed back pressure must be considered when selecting the specified burst pressure and determining the operating ratio. Consideration must also be given in the event the superimposed back pressure is inadvertently reduced below that which was used to specify the disk, since this could result in undesired disk activation.

2.3.6.1.5 For most closed systems the superimposed back pressure normally varies between some minimum and maximum pressure. For the particular rupture disk device being designed, the superimposed back pressure does not normally

include the pressure caused by other relief devices venting into the closed system unless that pressure would cause the relief pressure to exceed the code allowed accumulated pressure. However, the back pressure, caused by the venting of other relief devices, still needs to be considered when specifying the disk and may result in additions such as a vacuum or back pressure support to protect the disk.

2.3.6.2 Rupture Disk Device Specification

Accurately and completely documenting the process conditions and rupture disk device specifications is a key element in selecting the proper rupture disk. Appendix A provides a Rupture Disk Device Specification Sheet and step-by-step guidance for completing the specification sheet.

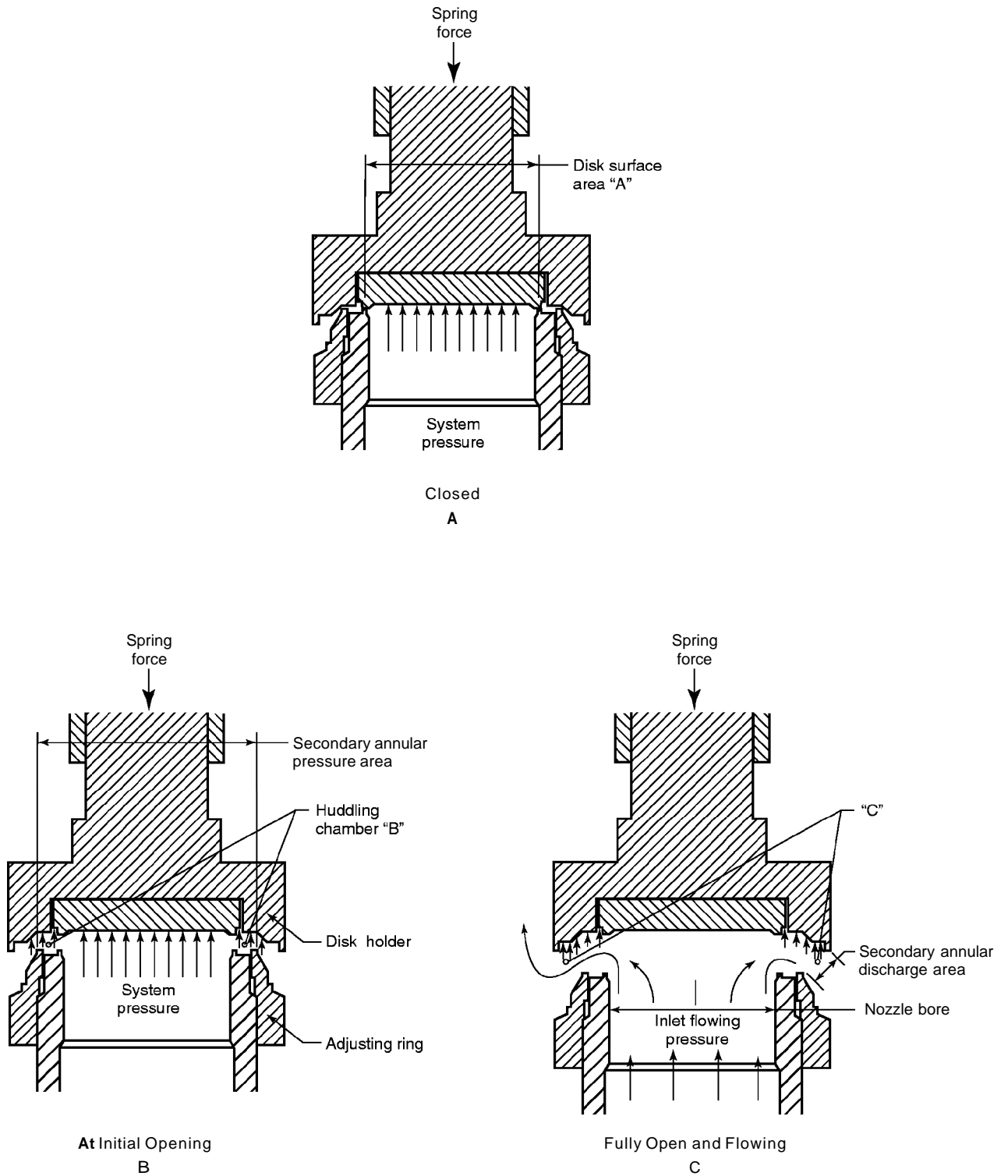

Figure 19—Pressure Relief Valve Operation—Vapor/Gas Service

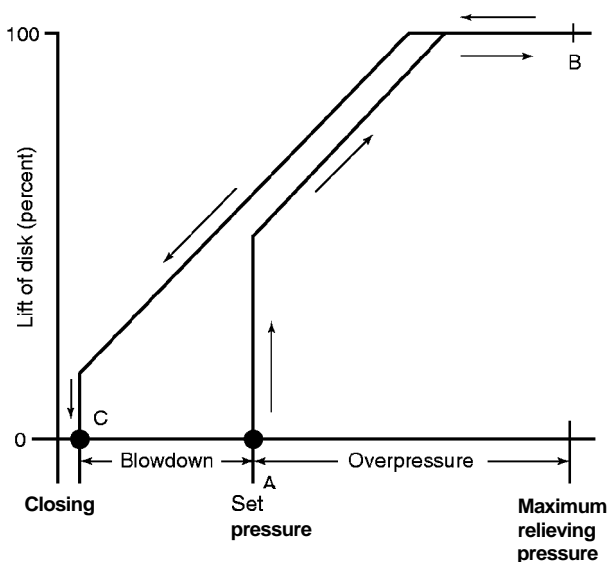

Figure 20—Typical Relationship Between Lift of Disk in a Pressure Relief Valve and Vessel Pressure

2.4 PIN-ACTUATED DEVICES

2.4.1 General

Pin-actuated pressure relief devices are non-reclosing devices consisting of a moving disc exposed to the pressure system, and an external mechanism housing a pin which is mechanically linked to the disc. Pins may be loaded in tension (breaking pins) or in compression (buckling pins, see Figure 18). The pin restrains the movement of the disc until the specified set pressure is reached. At this point the pin fails and the disc opens.

2.4.2 Buckling Pin Devices

Buckling pin devices, as shown in Figure 18, are compression-loaded pin-actuated devices and are the most extensively used type of pin-actuated device. Compression-loaded buckling pin devices are very stable and well suited to applications that have both cyclic operating conditions, and up to or above a 90% or greater ratio between operating pressure and set pressure.

Buckling pin devices may be sensitive to differential pressures. Operating conditions on both sides of the device need to be reviewed between the user and the manufacturer.

2.4.2.1 Set Pressure and Temperature

2.4.2.1.1 The set pressure of the pin-actuated device should be determined by the user, and an agreed tolerance either side of the nominal set pressure should be established with the manufacturer. The tolerance required per the ASME Code, Case 2091, is $\pm 5\%$.

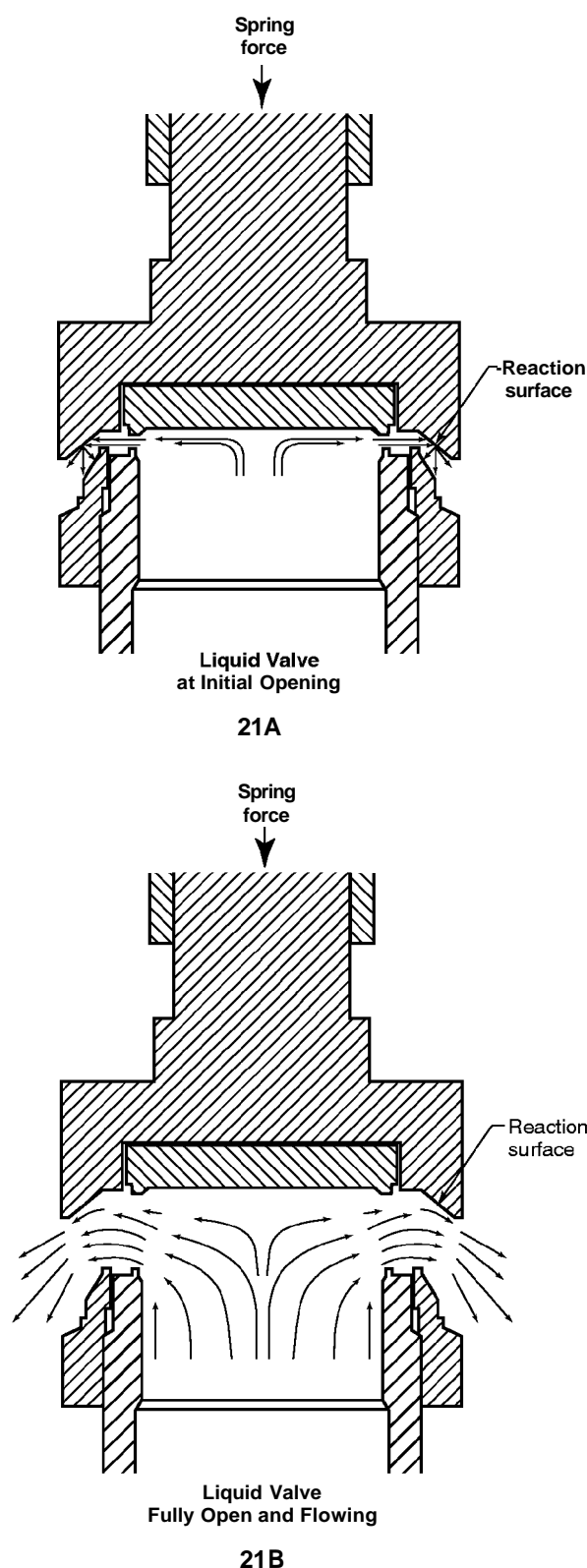
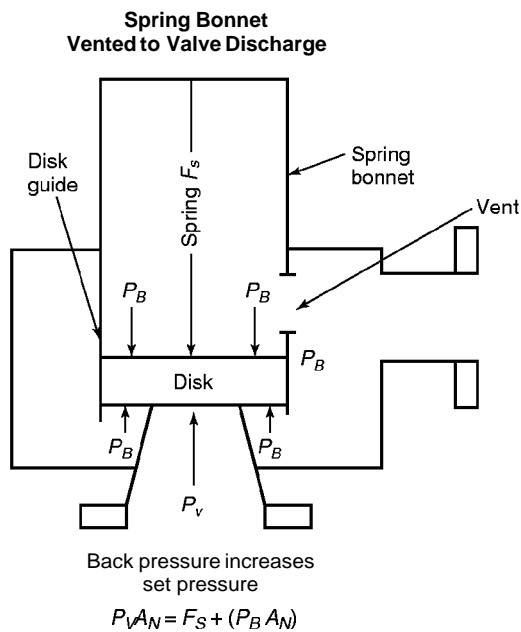

Figure 21—Pressure Relief Valve Operation—Liquid Service



- $A_D > A_N$
- A_D = disk area,
- A_N = nozzle seat area,
- F_S = spring force,
- P_V = vessel pressure in pounds per square inch gauge,
- P_B = superimposed back pressure, in pounds per square inch gauge.

Figure 22—Typical Effects of Superimposed Back Pressure on the Opening Pressure of Conventional Pressure Relief Valves

2.4.2.1.2 The wetted parts of the device must be designed to meet the process temperature to ensure that acceptable materials are selected. However, since the pin is external to the process, the pin is not exposed to the process temperature conditions but rather to the external environmental conditions. The pin, therefore, must be designed based on the external environmental temperature to ensure that the set pressure of the device is correctly established.

2.4.2.1.3 Compression-loaded buckling pins have a low sensitivity to temperature. If a pin device will see service over a wide range of environmental temperatures, or outside of an ambient temperature range, then advice concerning change in set pressure should be sought from the manufacturer. In some cases it may be recommended to conduct specific temperature testing of pins before delivery of the device.

2.4.2.2 Leak Tightness

2.4.2.2.1 The buckling pin device typically uses elastomer seals. The seal material should be carefully chosen to satisfy both the chemical conditions and the anticipated service tem-

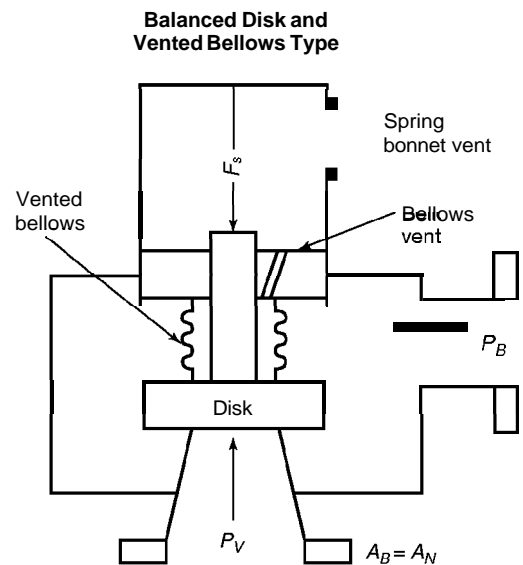
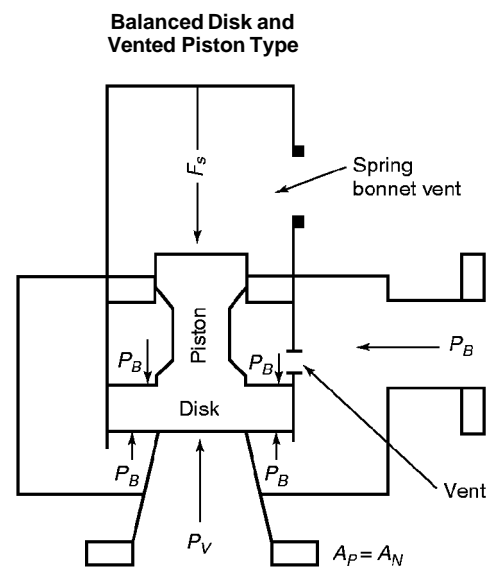

- A_B = effective bellows area,
- A_D = disk area,
- A_N = nozzle seat area,
- A_p = piston area (top),
- F_S = spring force,
- P_V = vessel gauge pressure,
- P_B = superimposed back pressure, in pounds per square inch gauge,
- P_S = set pressure, in pounds per square inch gauge.

Note: In this figure, $P_V = P_S$; $(P_V)(A_N) = F_S$ (typical); and $P_S = F_S/A_N$.

Figure 23—Typical Effects of Back Pressure on the Set Pressure of Balanced Pressure Relief Valves

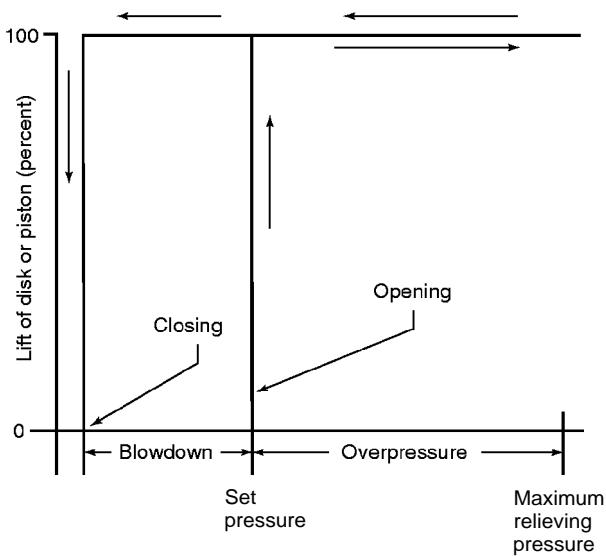

Figure 24—Typical Relationship Between Lift of Disk or Piston and Vessel Pressure in a Pop-Action Pilot-Operated Pressure Relief Valve

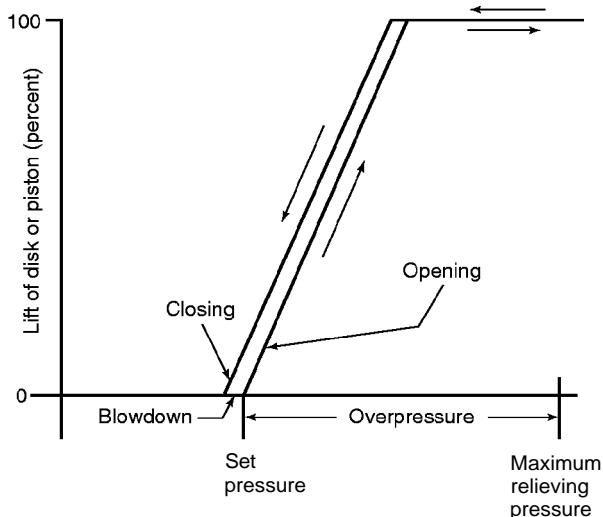

Figure 25—Typical Relationship Between Lift of Disk or Piston and Vessel Pressure in a Modulating-Action Pilot-Operated Pressure Relief Valve

parahires. It is recommended that the leak tightness of the device be tested per API RP 527 before shipment by the manufacturer.

2.4.2.2.2 If the application is vacuum service and/or back pressure exists, the manufacturer needs to be notified to ensure proper sealing under such conditions.

2.4.2.3 Marking and Tagging

The buckling pin device should be clearly marked to indicate the direction of flow, set pressure, nominal size, serial number and model or type designation, materials of construction, and the manufacturer. Each pin, or a tag attached to each pin, should be marked with the manufacturer, lot number, device model or type, set pressure and pin/device identifier. The lot number should appear on the manufacturer's certification report together with the serial number of the device or the device identifier for which the pins have been calibrated.

2.4.3 Breaking Pin Devices

2.4.3.1 A breaking pin device is a non-reclosing pressure relief device with a movable disc held in the closed position by a pin loaded in tension. When pressure reaches the set pressure of the device, the pin breaks and the disc opens. Breaking pin devices are generally used in combination with a pressure relief valve where valve tightness is of concern, for example, in corrosive or vibrating environments such as on fluid transport vessels.

2.4.3.2 The *ASME Boiler and Pressure Vessel Code*, Section VIII, allows breaking pin devices to be used only in combination with pressure relief valves. Breaking pin devices are designed to operate at a specified differential pressure. If pressure is allowed to build up on the downstream side of the breaking pin device, the opening pressure will be increased. It is required, therefore, that the space between a breaking pin device and a pressure relief valve be provided with a gauge, trycock, free vent or suitable telltale indicator to detect any build-up of pressure in that cavity.

2.5 OTHER TYPES OF DEVICES

Other pressure relief devices not described in this section are occasionally specified in refineries and related industries. Users should consult the manufacturer for information about designs and special applications.

3 Procedures for Sizing

3.1 DETERMINATION OF RELIEF REQUIREMENTS

3.1.1 To establish the size and design of a pressure relief device for any application, the designer must first determine the conditions for which overpressure protection may be required. Reasonable care should be exercised in establishing the various contingencies that could result in overpressure.

3.1.2 The contingencies that may cause overpressure must be evaluated in terms of the pressures generated and the rates at which fluids must be relieved. The process flow diagram, material balance, piping and instrument diagrams, equipment specification sheets, and design basis for the facility are

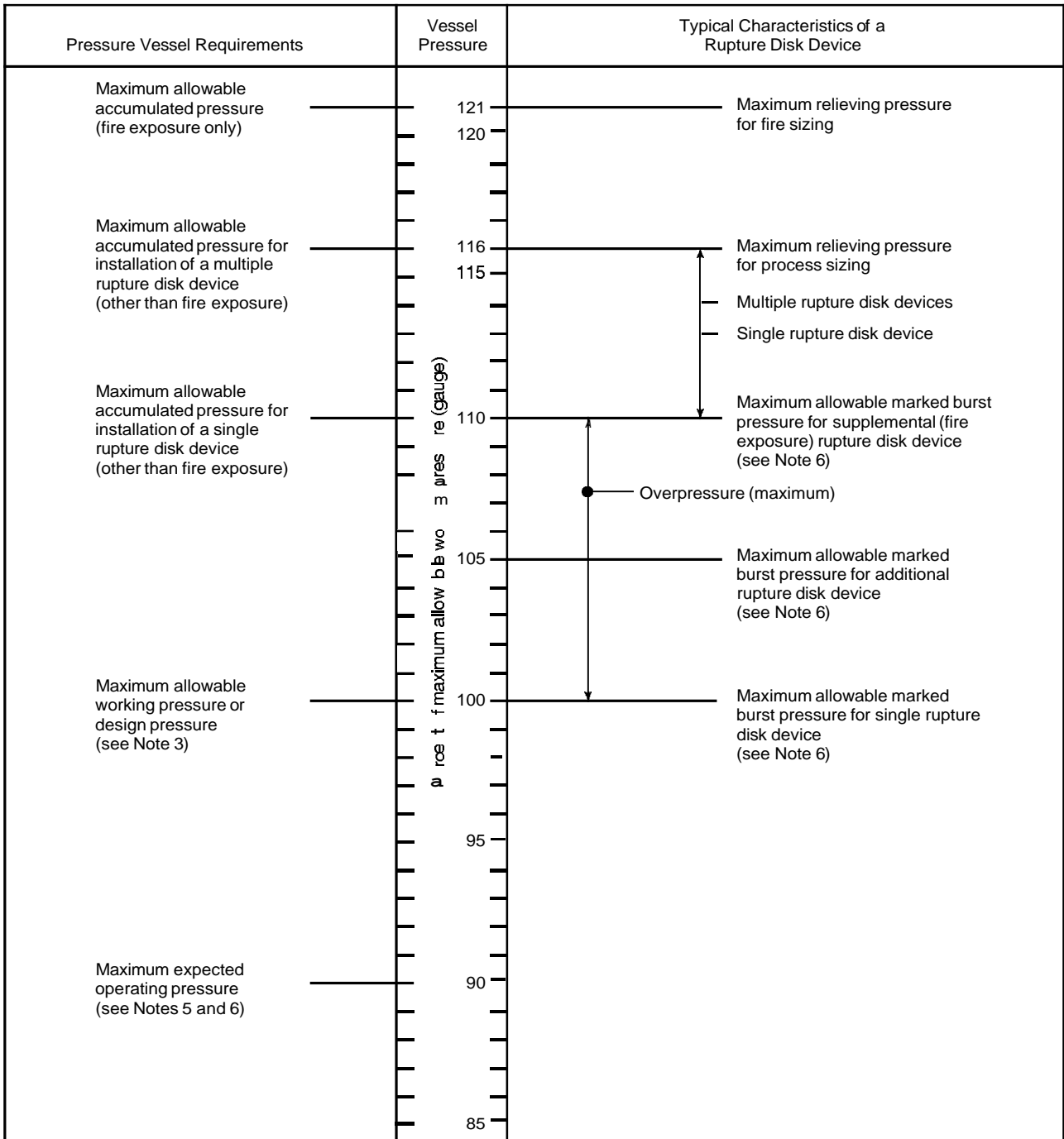

Notes:

1. This figure conforms with the requirements of Section VIII of the ASME *Boiler and Pressure Vessel Code* for MAWPs greater than 30 psi.
2. The pressure conditions shown are for rupture disk devices installed on a pressure vessel.
3. The margin between the maximum allowable working pressure and the operating pressure must be considered in the selection of a rupture disk.
4. The allowable burst-pressure tolerance will be in accordance with the applicable code.
5. The operating pressure may be higher or lower than 90 depending on the rupture disk design.
6. The marked burst pressure of the rupture disk may be any pressure at or below the maximum allowable marked burst pressure.

Figure 26 — Pressure-Level Relationships for Rupture Disk Devices

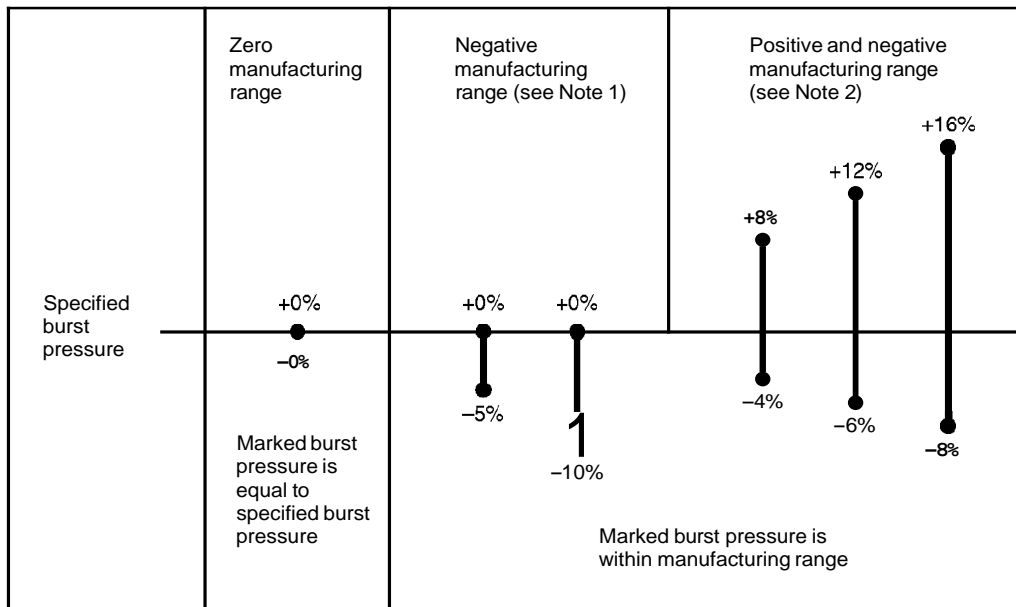

Notes:

1. The marked burst pressure will not exceed the specified burst pressure.
2. Positive manufacturing range may result in a marked burst pressure exceeding the specified burst pressure.

Figure 27—Common Types of Manufacturing Ranges and Corresponding Burst Pressure Marking

needed to calculate the individual relieving rates for each pressure relief device. Process equipment vendor data is also helpful if available.

3.1.3 Table 2 of API RP 521 lists a number of common operational conditions for which overpressure protection may be required. This list is by no means complete; each plant may have unique features that must be considered in addition to those listed. API RP 521 provides a detailed discussion of relief requirements for these emergency operating conditions. API RP 521 also provides a detailed discussion of the relief requirements for the special case of fire.

3.2 API EFFECTIVE AREA AND EFFECTIVE COEFFICIENT OF DISCHARGE

3.2.1 Pressure relief valves may be initially sized using the equations presented in 3.6 through 3.10 as appropriate for vapors, gases, liquids, or two phase fluids. These equations utilize effective coefficients of discharge and effective areas which are independent of any specific valve design. In this way, the designer can determine a preliminary pressure relief valve size.

3.2.2 The designer can then use API Std 526, *Flanged Steel Pressure Relief Valves*, to select a pressure relief valve. API Std 526 is a purchase specification for steel flanged valves. This standard lists specific valve configurations specified by

inlet/outlet size and flange configuration, materials of construction, pressure/temperature limits, inlet and outlet center to face dimensions, and effective orifice designation. When a valve is specified per this standard, the orifice size is expressed in terms of a letter designation ranging from the smallest, "D," to the largest, "T." An effective area is specified for each letter orifice.

3.2.3 Sections 3.6 through 3.10 provide sizing information which may be used for the initial selection of a pressure relief valve from the incremental D through T orifice sizes specified in API Std 526. The effective orifice areas listed in API Std 526 and the effective coefficient of discharge used for the initial selection, are nominal values not directly related to a specific valve design.

3.2.4 The rated coefficient of discharge for a pressure relief valve determined per the applicable certification standards is generally less than the effective coefficient of discharge used in API RP 520 (particularly for vapor service valves where the effective coefficient of discharge is 0.975). This is true of valves certified per the rules of the *ASME Boiler and Pressure Vessel Code* where the average coefficient from a series of valve test results is multiplied by 0.9 to establish a rated coefficient of discharge. For this reason, the actual discharge or orifice area for most valve designs is greater than the effective discharge area specified for that valve size per API Std 526. This allows the rated

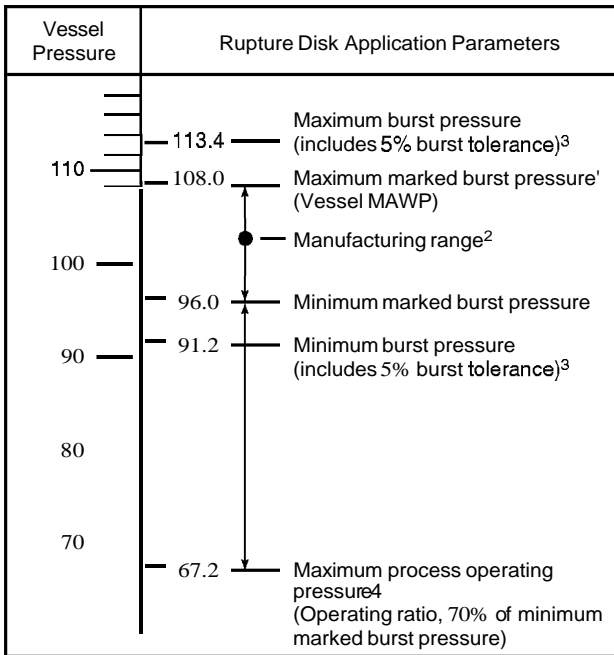

A. Example of a rupture disk with a specified burst pressure of 100 psig, manufacturing range of +8/-4%, burst tolerance of ±5%, and a 70% operating ratio.

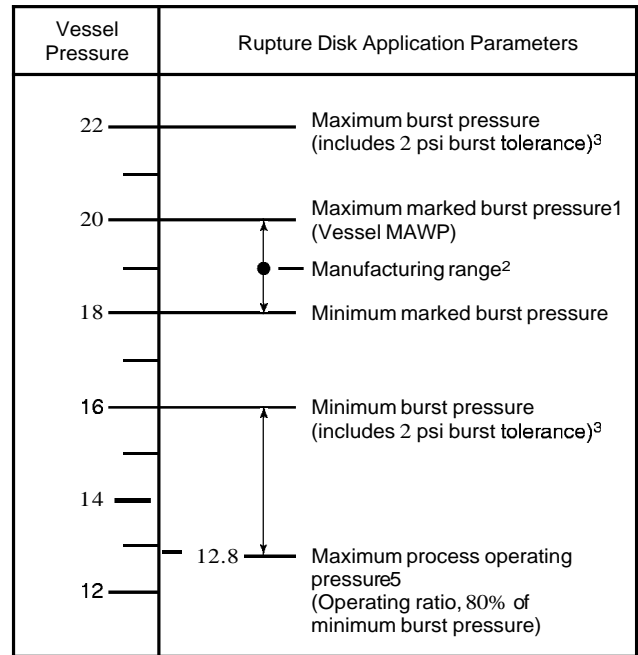

C. Example of a rupture disk with a specified burst pressure of 20 psig, manufacturing range of +0/-10%, burst tolerance of ±2 psi, and an 80% operating ratio.

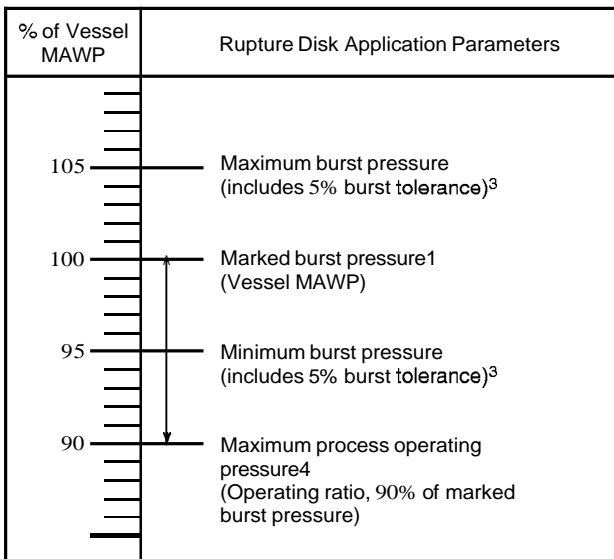

B. Example of a rupture disk with a specified burst pressure of 100 psig, zero manufacturing range, burst tolerance of ±5%, and a 90% operating ratio.

Notes:

1. See Figure 26 for limits on marked burst pressure.
2. Marked burst pressure may be any pressure within the manufacturing range, see Figure 27.
3. For marked burst pressures above 40 psig, the burst tolerance is ±5%. For marked burst pressures at 40 psig and below, the burst tolerance is ±2 psi.
4. For marked burst pressures above 40 psig, the maximum process operating pressure is calculated by multiplying the minimum marked burst pressure by the operating ratio.
5. For marked burst pressures at 40 psig and below, the maximum process operating pressure is calculated by subtracting the burst tolerance from the minimum marked burst pressure, then multiplying the difference by the operating ratio.

Figure 28—Rupture Disk Application Parameters (Each example assumes zero superimposed backpressure)

capacity of most valve designs to meet or exceed the estimated capacity for preliminary sizing determined per the API RP 520 calculations.

3.2.5 When a specific valve design is selected for the application, the rated capacity of that valve can be determined using the actual orifice area, the rated coefficient of discharge and the equations presented in this document. This rated relieving capacity is then used to verify that the selected valve has sufficient capacity to satisfy the application. It is important to remember that the effective area and the effective coefficient of discharge are used only for the initial selection. The actual orifice area and the rated coefficient of discharge must always be used to verify the actual capacity of the pressure relief valve. In no case should an effective area or effective coefficient of discharge be used with an actual area or rated coefficient of discharge for calculating the capacity of a pressure relief valve.

3.2.6 In summary, the effective orifice size and effective coefficient of discharge specified in API Standards are assumed values used for initial selection of a pressure relief valve size from configurations specified in API Std 526, independent of an individual valve manufacturer's design. In most cases, the actual area and the rated coefficient of discharge for an API letter orifice valve are designed so that the actual certified capacity meets or exceeds the capacity calculated using the methods presented in API RP 520. There are, however, a number of valve designs where this is not so. When the pressure relief valve is selected, therefore, the actual area and rated coefficient of discharge for that valve must be used to verify the rated capacity of the selected valve and to verify that the valve has sufficient capacity to satisfy the application.

3.3 BACK PRESSURE

3.3.1 General

3.3.1.1 Pressure existing at the outlet of a pressure relief valve is defined as back pressure. Regardless of whether the valve is vented directly to atmosphere or the discharge is piped to a collection system, the back pressure may affect the operation of the pressure relief valve. Effects due to back pressure may include variations in opening pressure, reduction in flow capacity, instability, or a combination of all three.

3.3.1.2 Back pressure which is present at the outlet of a pressure relief valve when it is required to operate is defined as superimposed back pressure. This back pressure can be constant if the valve outlet is connected to a process vessel or system which is held at a constant pressure. In most cases, however, the superimposed back pressure will be variable as a result of changing conditions existing in the discharge system.

3.3.1.3 Back pressure which develops in the discharge system after the pressure relief valve opens is defined as built-up

back pressure. Built-up back pressure occurs due to pressure drop in the discharge system as a result of flow from the pressure relief valve. Short tailpipes that vent directly to the atmosphere typically result in lower built-up back pressures than long discharge systems. However, choked flow can occur at the outlet of even short tailpipes vented directly to atmosphere, resulting in a high built-up back pressure. For this reason, the magnitude of the built-up back pressure should be evaluated for all systems, regardless of the outlet piping configuration.

3.3.1.4 The magnitude of the back pressure which exists at the outlet of a pressure relief valve, after it has opened, is the total of the superimposed and the built-up back pressure.

3.3.2 Effects of Superimposed Back Pressure on Pressure Relief Valve Opening

3.3.2.1 Superimposed back pressure at the outlet of a conventional spring loaded pressure relief valve acts to hold the valve disc closed with a force additive to the spring force. The actual spring setting can be reduced by an amount equal to the superimposed back pressure to compensate for this [see 3.4 for discussion of cold differential test pressure (CDTP)].

3.3.2.2 Balanced pressure relief valves (see 2.2.1.3) utilize a bellows or piston to minimize or eliminate the effect of superimposed back pressure on set pressure. Many pilot operated pressure relief valves have pilots which are vented to atmosphere or are balanced to maintain set pressure in the presence of variable superimposed back pressure. Balanced spring-loaded or pilot-operated pressure relief valves should be considered if the superimposed back pressure is variable. However, if the amount of variable superimposed back pressure is small, a conventional valve could be used provided:

- The set pressure has been compensated for any superimposed back pressure normally present; and
- The maximum pressure during relief does not exceed the Code-allowed limits for accumulation in the equipment being protected.

3.3.2.3 For example, conventional valves are often used when the outlet is piped into a relief header without compensating the set pressures for the superimposed back pressure caused by other relieving devices. This approach can be used provided the allowable accumulation is not exceeded during the release.

3.3.3 Effects of Back Pressure on Pressure Relief Valve Operation and Flow Capacity

3.3.3.1 Conventional Pressure Relief Valves

3.3.3.1.1 Conventional pressure relief valves show unsatisfactory performance when excessive back pressure develops during a relief incident, due to the flow through the valve and outlet piping. The back pressure tends to reduce the lifting force which is holding the valve open.

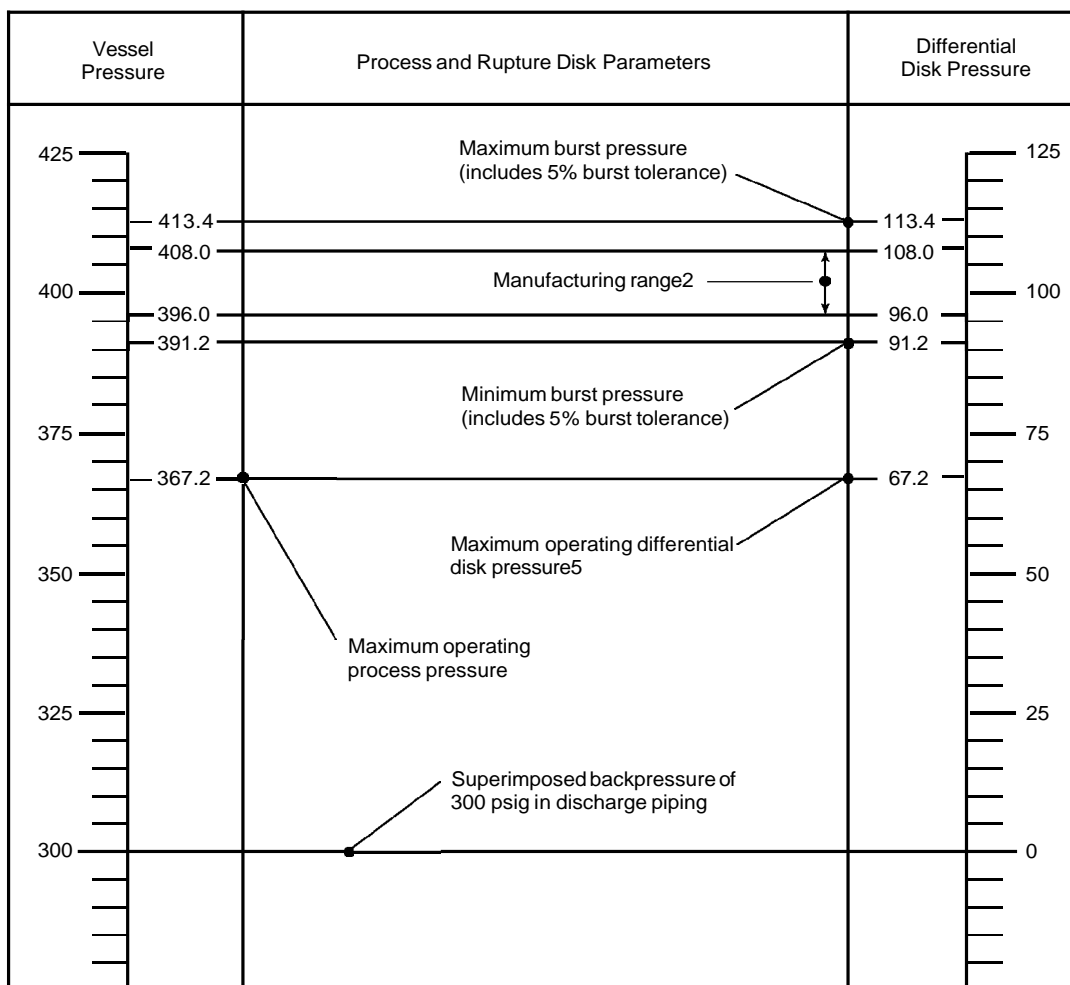

Notes:

- This figure is an example of a rupture disk with a:
 - Specified burst pressure of 100 psi.
 - Manufacturing range of $+8/-4\%$.
 - Burst pressure tolerance of $\pm 5\%$.
 - Operating ratio of 70% ($0.7 \times 96.0 \text{ psi} = 67.2 \text{ psi}$).
 - Superimposed backpressure of 300 psi.
 - Vessel MAWP equal to or greater than 408 psi.
- The disk used in this figure is intended to be identical with the disk in Figure 28A. The disks are interchangeable. The disk in this figure (and in Figure 28A) may be marked anywhere in the manufacturing range, from 96 psi to 108 psi.
- The superimposed backpressure in this example is larger than normally encountered to amplify the difference between vessel pressure and differential pressure across the rupture disk.
- The differential disk pressure is equal to the vessel pressure minus the superimposed backpressure.
- The user is cautioned not to exceed the maximum operating differential disk pressure throughout the process cycle, including start-up and shutdown.

Figure 29—Rupture Disk Application Parameters
(With Superimposed Backpressure)

3.3.3.1.2 Excessive built-up back pressure can cause the valve to operate in an unstable manner. This instability may occur as flutter or chatter. Chatter refers to the abnormally rapid reciprocating motion of the pressure relief valve disc where the disc contacts the pressure relief valve seat during cycling. This type of operation may cause damage to the valve and interconnecting piping. Flutter is similar to chatter except that the disc does not come into contact with the seat during cycling.

3.3.3.1.3 In a conventional pressure relief valve application, built-up back pressure should not exceed 10% of the set pressure at 10% allowable overpressure. A higher maximum allowable built-up back pressure may be used for allowable overpressures greater than 10% provided the built-up back pressure does not exceed the allowable overpressure. When the superimposed back pressure is constant, the spring load may be reduced to compensate for the superimposed back pressure. In this case, it is recommended that the built-up back pressure should not exceed the allowable overpressure. When the downstream piping is designed within the above back pressure criteria, no back pressure capacity correction ($K_b = 1.0$) is required in the valve sizing equations, for gases at critical flow or for liquids. When the back pressure is expected to exceed these specified limits, a balanced or pilot-operated pressure relief valve should be specified.

3.3.3.2 Balanced Pressure Relief Valves

3.3.3.2.1 A balanced pressure relief valve should be used where the built-up back pressure is too high for conventional pressure relief valves or where the superimposed back pressure varies widely compared to the set pressure. Balanced valves can typically be applied where the total back pressure (superimposed plus built-up) does not exceed approximately 50% of the set pressure. The specific manufacturer should be consulted concerning the back pressure limitation of a particular valve design. With a balanced valve, high back pressure will tend to produce a closing force on the unbalanced portion of the disc. This force may result in a reduction in lift and an associated reduction in flow capacity. Capacity correction factors, called back pressure correction factors, are provided by manufacturers to account for this reduction in flow. Typical back pressure correction factors may be found for compressible fluid service in Figure 30 and for incompressible fluid (liquid) service in Figure 31. For liquid service applications, the factor shown in Figure 31 is applicable for all overpressures. For compressible fluid service, however, the factor may vary depending on whether the allowable overpressure is 10%, 16%, or 21% (Note that the back pressure correction factors from Figures 30 and 31 are suitable for the preliminary sizing procedures found in this document. Final sizing calculations should always be completed using the manufacturer's actual charts). In some applications, set pressure may be significantly less than MAWP allowing for overpressures

in excess of those specified above. In such cases, the manufacturer should be consulted for guidance.

3.3.3.2.2 In most applications, the allowable overpressure is 10% and the back pressure correction factor for 10% overpressure must be used. In the special case of multiple valve installations, the low set valve may operate at overpressures up to 16%. A back pressure correction factor for 16% overpressure may be used for that low set valve. The high set valve is actually operating at a maximum overpressure of 10% (assuming the high set valve is set at 105% of the MAW), however, and the back pressure correction factor for 10% overpressure must be used for that high set valve. A supplemental valve used for an additional hazard created by exposure to fire (see 3.5.3.4), may be set to open at 10% above MAW. In this case, the back pressure correction factor for 10% overpressure must be used because the valve is actually operating at 10% overpressure, even though the accumulation is at 21%. When calculating the additional capacity for the first (nonfire) valve at 21% overpressure (see Figure 30, note 3), a back pressure correction factor of 1.0 may be used.

3.3.3.2.3 The back pressure correction factors specified in Figures 30 and 31 are applicable to balanced spring-loaded pressure relief valves with back pressures up to 50% of set pressure.

3.3.3.2.4 When back pressures in compressible fluid applications (does not include multiphase applications) exceed approximately 50% of set pressure, the flow is subcritical. In this case, the formulas found in 3.6.2 should be used. The pressure relief valve manufacturer should be consulted when back pressures exceed approximately 50% of set pressure to obtain back pressure correction factors or any special limitations on valve operation.

3.3.3.3 Pilot-Operated Pressure Relief Valves

For pilot operated pressure relief valves, the valve lift is not affected by back pressure. For compressible fluids at critical flow conditions, a back pressure correction factor of 1.0 should be used for pilot-operated pressure relief valves.

3.3.4 Effects of Back Pressure and Header Design on Pressure Relief Valve Sizing and Selection

3.3.4.1 For conventional relief valves connected to a flare header, there are several considerations that affect relief valve sizing and selection. The pressure relief valve discharge line and flare header must be designed so that the built-up back pressure does not exceed the allowable limits as specified in 3.3.3. In addition, the flare header system must be designed in order to insure that the superimposed back pressure, caused by venting or relief from another source, will not prevent

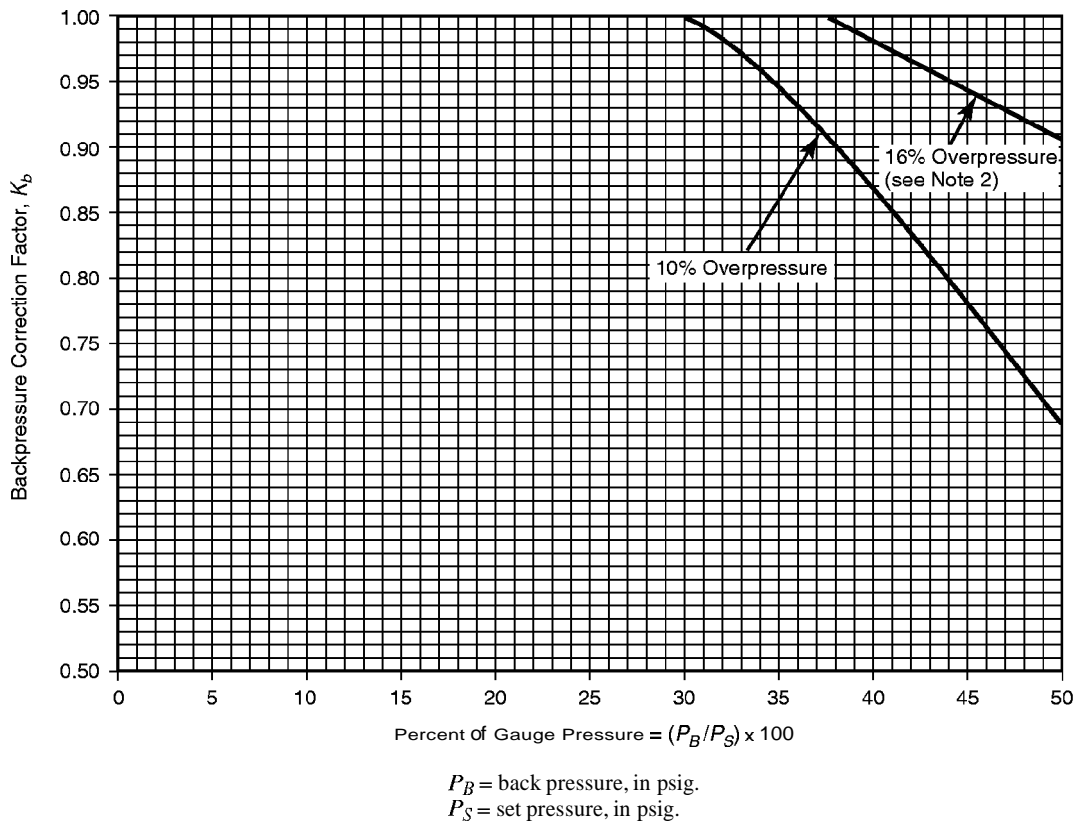

Notes:

1. The curves above represent a compromise of the values recommended by a number of relief valve manufacturers and may be used when the make of the valve or the critical flow pressure point for the vapor or gas is unknown. When the make of the valve is known, the manufacturer should be consulted for the correction factor. These curves are for set pressures of 50 psig and above. They are limited to back pressure below critical flow pressure for a given set pressure. For set pressures below 50 psig or for subcritical flow, the manufacturer must be consulted for values of K_b .
2. See paragraph 3.3.3.
3. For 21% overpressure, K_b equals 1.0 up to $P_B/P_S = 50\%$.

Figure 30—Back Pressure Correction Factor, K_b , for Balanced-Bellows Pressure Relief Valve (Vapors and Gases)

relief valves from opening at a pressure adequate to protect equipment per the ASME or applicable code. Once the superimposed, built-up, and total back pressures are calculated based on a pressure drop analysis of the discharge system, they should be specified on the data sheet for the pressure relief valve under consideration.

3.3.4.2 For a balanced pressure relief valve, superimposed back pressure will not affect the set pressure of the relief valve. However, total back Pressure may affect the capacity of the relief valve. Sizing a balanced pressure relief valve is a two-step process. The relief valve is sized using a preliminary back pressure correction factor, K_b . The correction factor could either be set initially equal to 1.0 or can be based on an assumed total back pressure. Once a preliminary valve size

and capacity is determined, the discharge line and header size can be determined based on pressure drop calculations. The final size, capacity, back pressure, and back pressure correction factor, K_b , can then be calculated. The back pressure should be included on the data sheet for the pressure relief valve under consideration.

3.3.4.3 For a pilot-operated pressure relief valve, neither the set pressure nor the capacity is typically affected by back pressure, for compressible fluids at critical flow conditions. Tail pipe and flare header sizing are typically based on other considerations.

3.3.4.4 Outlet pipe sizing and flare header sizing are discussed in more detail in API RP 520, Part 2, and API RP 521.

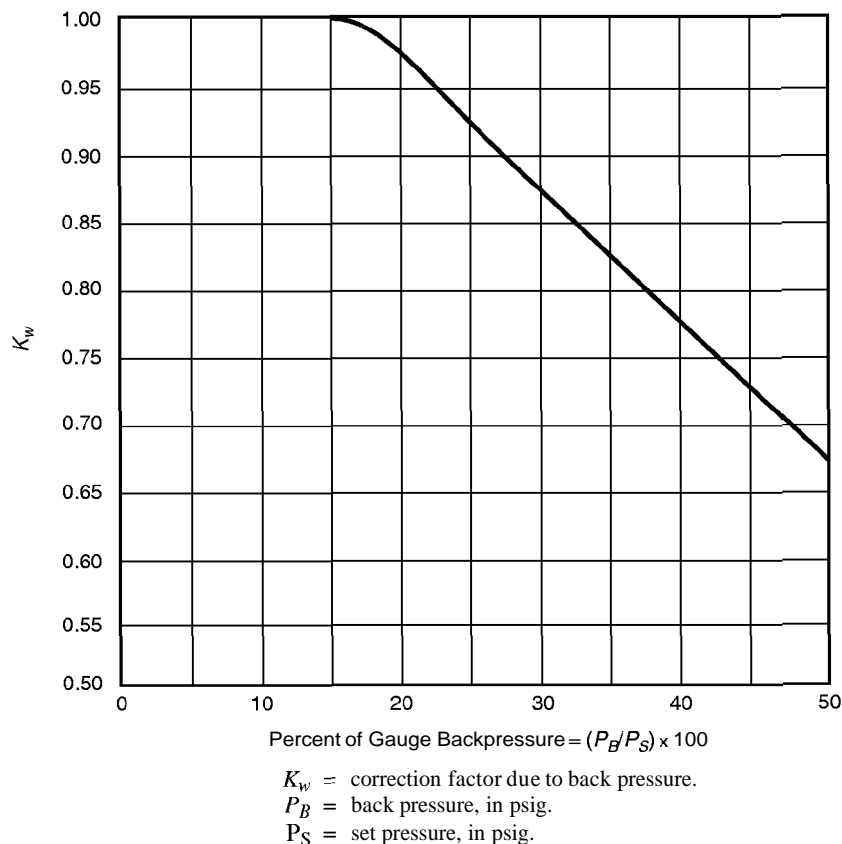

Note: The curve above represents values recommended by various manufacturers. This curve may be used when the manufacturer is not known. Otherwise, the manufacturer should be consulted for the applicable correction factor.

Figure 31—Capacity Correction Factor, K_w , Due to Back Pressure on Balanced-Bellows Pressure Relief Valves in Liquid Service

3.4 COLD DIFFERENTIAL TEST PRESSURE (CDTP)

3.4.1 The actual service conditions under which a pressure relief valve is required to open, may be different from the conditions at which the pressure relief valve is set to operate on a test stand. To compensate for this effect, a CDTP is specified for adjusting the set pressure of the valve on the test stand. The CDTP may include a correction for actual service conditions of back pressure and/or temperature.

3.4.2 A temperature correction factor (multiplier) is typically required when the relieving temperature exceeds 250°F. The factor compensates for variations in spring load due to thermal growth in valve components as well as changes in the spring material properties. Compensation may also be required for low temperature service below -75°F. When such temperature compensation is required, the correction factor should be obtained from the pressure relief valve manufacturer.

3.4.3 A conventional pressure relief valve, operating with a constant superimposed back pressure, normally requires a correction factor to compensate for the back pressure. In this case the required set pressure minus the superimposed back pressure, is equal to the CDTP. This change accounts for the additional closing force exerted on the valve disk by the back pressure. In the case of a balanced spring loaded pressure relief valve, the change in closing force due to the superimposed back pressure is negligible and no correction is required.

3.4.4 When the CDTP is to include correction for back pressure and temperature, the differential pressure is calculated and then multiplied by the temperature correction to determine the CDTP.

3.4.5 Pilot-operated pressure relief valves (see 2.2.2) may require a CDTP when used in high temperature or back pressure service. The valve manufacturer should be consulted regarding back pressure and temperature limits, and required correction factors.

3.5 RELIEVING PRESSURE

3.5.1 General

3.5.1.1 Relieving pressure, shown as P_1 in the various sizing equations, is the inlet pressure of the pressure relief device at relieving conditions. The relieving pressure is the total of set pressure plus overpressure. The examples cited in this section for the determination of relieving pressure refer to pressure relief valves, however, they are also applicable to non-reclosing pressure relief devices. (See Figures 1 and 26 for pressure level relationships for these types of devices.)

3.5.1.2 The allowable overpressure is established from the accumulation permitted by the applicable code. The allowable overpressure may vary for different applications depending on the relationship of the set pressure to the maximum allowable working pressure of the vessel or system that is protected. Allowable overpressure is the same as allowable accumulation only when the set pressure is equal to the maximum allowable working pressure.

Note: The discussion in this section generally cites the ASME Code as the applicable code. Unless stated otherwise, citations refer only to Section VIII of the ASME Code. The designer should be aware of revisions to the ASME Code. If pertinent revisions occur, the discussion in this section should be adjusted accordingly by the designer. Adjustments may also be required by the designer if other (non-ASME) codes apply.

3.5.1.3 Sections 3.5.2 through 3.5.3 discuss methods of determining the relieving pressure for pressure relief valves in gas and vapor service. Standard atmospheric pressure (14.7 psia 101.4 kPa) is used for gauge/absolute pressure conversion in these sections. For design, barometric pressure corresponding to site elevation should be used.

3.5.1.4 Relieving pressure for pressure relief valves in liquid service is determined in a manner similar to that used for vapor service. In the case of liquid service valves used in

ASME applications, the relieving pressure and maximum allowable accumulation is determined as described in paragraphs 3.5.2 through 3.5.3. In applications where these paragraphs do not apply, alternate accumulations are sometimes specified, as required by other Codes or the equipment manufacturer.

3.5.1.5 Table 1 summarizes the maximum accumulation and set pressure for pressure relief valves specified in accordance with the ASME Code.

3.5.2 Operating Contingencies

3.5.2.1 Single-Device Installation

3.5.2.1.1 In accordance with the requirements of the ASME Code, Section VIII, Division 1, accumulated pressure shall be limited to 110% of the maximum allowable working pressure, MAWP, in vessels that are protected by a single pressure relief device sized for operating (nonfire) contingencies. The set pressure of the device shall not exceed the MAW.

3.5.2.1.2 Note that in accordance with the ASME Code, the allowable accumulation is 3 psi (21 kPa) when the MAWP is between 15 and 30 psig (103 and 207 kPa).

3.5.2.1.3 Table 2 shows an example determination of relieving pressure for a single device whose set pressure is less than or equal to the vessel's MAW.

3.5.2.2 Multiple-Device Installation

3.5.2.2.1 A multiple-device installation requires the combined capacity of two or more pressure relief devices to alleviate a given overpressure contingency.

3.5.2.2.2 In accordance with the requirements of the ASME Code, Section VIII, Division 1, accumulated pressure

Table 1—Set Pressure and Accumulation Limits for Pressure Relief Valves

Contingency	Single-Valve Installations		Multiple-Valve Installations	
	Maximum Set Pressure (percent)	Maximum Accumulated Pressure (percent)	Maximum Set Pressure (percent)	Maximum Accumulated Pressure (percent)
Nonfire Cases				
First valve	100	110	100	116
Additional valve(s)	—	—	105	116
Fire Case				
First valve	100	121	100	121
Additional valve(s)	—	—	105	121
Supplemental valve	—	—	110	121

Note: All values are percentages of the maximum allowable working pressure.

Table 2—Example Determination of Relieving Pressure for a Single-Valve Installation (Operating Contingencies)

Characteristic	Value
Valve Set Pressure Less than MAWP	
Protected vessel MAWP, psig	100.0
Maximum accumulated pressure, psig	110.0
Valve set pressure, psig	90.0
Allowable overpressure, psi	20.0
Relieving pressure, P_1 , psia	124.7
Valve Set Pressure Equal to MAWP	
Protected vessel MAWP, psig	100.0
Maximum accumulated pressure, psig	110.0
Valve set pressure, psig	100.0
Allowable overpressure, psi	10.0
Relieving pressure, P_1 , psia	124.7

shall be limited to 116% of the maximum allowable working pressure, MAW in vessels that are protected by multiple pressure relief devices sized for operating (nonfire) contingencies. The set pressure of the first device shall not exceed the MAW. The set pressure of the additional device or devices shall not exceed 105% of the MAWP.

3.5.2.2.3 Note that the allowable accumulation is 4 psi (28 kPa) when the MAWP is between 15 and 30 psig (103 and 207 kPag).

3.5.2.2.4 Table 3 shows an example determination of the relieving pressure for a multiple-device installation in which the set pressure of the first device is equal to the MAWP of the vessel, and the set pressure of the additional device is 105% of the vessel's MAW.

3.5.3 Fire Contingencies

3.5.3.1 General

3.5.3.1.1 In accordance with the requirements of the ASME Code, Section VIII, Division 1, accumulated pressure shall be limited to 121% of the maximum allowable working pressure, MAWP, in vessels that are protected by pressure relief devices sized for fire contingencies. This applies to single-, multiple-, and supplemental-device installations.

3.5.3.1.2 Single or multiple devices sized for fire may also be utilized for relieving requirements attributed to operating (nonfire) contingencies, provided that the constraint of 110% and 116% (of the MAW) accumulated pressure for the non-fire contingencies is observed.

Table 3—Example Determination of Relieving Pressure for a Multiple-Valve Installation (Operating Contingencies)

Characteristic	Value
First Valve (Set Pressure Equal to MAW)	
Protected vessel MAWP, psig	100.0
Maximum accumulated pressure, psig	116.0
Valve set pressure, psig	100.0
Allowable overpressure, psi	16.0
Relieving pressure, P_1 , psia	130.7
Additional Valve (Set Pressure Equal to 105% of MAWP)	
Protected vessel MAW, psig	100.0
Maximum accumulated pressure, psig	116.0
Valve set pressure, psig	105.0
Allowable overpressure, psi	11.0
Relieving pressure, P_1 , psia	130.7

3.5.3.2 Single-Device Installation

3.5.3.2.1 Where a vessel is protected by a single device sized for fire, the set pressure shall not exceed the maximum allowable working pressure, MAW.

3.5.3.2.2 Table 4 shows an example determination of relieving pressure for a single device whose set pressure is less than or equal to the vessel's MAW.

3.5.3.3 Multiple-Device Installation

3.5.3.3.1 A multiple-device installation requires the combined capacity of two or more devices to alleviate overpressure. The set pressure of the first device to open shall not exceed the maximum allowable working pressure, MAW. The set pressure of the last device to open shall not exceed 105% of the MAW.

3.5.3.3.2 Table 5 shows an example determination of relieving pressure for a multiple-device installation in which the set pressure of the first device is equal to the vessel's MAW, and the set pressure of the additional device is 105% of the vessel's MAWP.

3.5.3.4 Supplemental-Device Installation

3.5.3.4.1 A supplemental-device installation provides relieving capacity for an additional hazard created by exposure to fire or other unexpected sources of external heat. The

Table 4—Example Determination of Relieving Pressure for a Single-Valve Installation (Fire Contingencies)

Characteristic	Value
Valve Set Pressure Less than MAWP	
Protected vessel MAWP, psig	100.0
Maximum accumulated pressure, psig	121.0
Valve set pressure, psig	90.0
Allowable overpressure, psi	31.0
Relieving pressure, P_1 , psia	135.7
Valve Set Pressure Equal to MAWP	
Protected vessel MAWP, psig	100.0
Maximum accumulated pressure, psig	121.0
Valve set pressure, psig	100.0
Allowable overpressure, psi	21.0
Relieving pressure, P_1 , psia	135.7

Table 5—Example Determination of Relieving Pressure for a Multiple-Valve Installation (Fire Contingencies)

Characteristic	Value
First Valve (Set Pressure Equal to MAWP)	
Protected vessel MAWP, psig	100.0
Maximum accumulated pressure, psig	121.0
Valve set pressure, psig	100.0
Allowable overpressure, psi	21.0
Relieving pressure, P_1 , psia	135.7
Additional Valve (Set Pressure Equal to 105% MAWP)	
Protected vessel MAWP, psig	100.0
Maximum accumulated pressure, psig	121.0
Valve set pressure, psig	105.0
Allowable overpressure, psi	16.0
Relieving pressure, P_1 , psia	135.7

set pressure of a supplemental device for fire shall not exceed 110% of the maximum allowable working pressure, MAWP.

3.5.3.4.2 Supplemental devices are used only in addition to devices sized for operating (nonfire) contingencies.

3.5.3.4.3 Table 6 shows an example determination of relieving pressure for a supplemental device installation in which the set pressure of the first (nonfire) device does not exceed the vessel's MAWP (see 3.5.1 for determination of relieving pressure), and the set pressure of the supplemental device is 110% of the vessel's MAWP.

Table 6—Example Determination of Relieving Pressure for a Supplemental-Valve Installation (Fire Contingencies)

Characteristic	Value
First Valve (Set Pressure Equal to MAWP)	
Protected vessel MAWP, psig	100.0
Maximum accumulated pressure, psig	121.0
Valve set pressure, psig	100.0
Allowable overpressure, psi	21.0
Relieving pressure, P_1 , psia	135.7
Supplemental Valve (Set Pressure Equal to 110% MAWP)	
Protected vessel MAWP, psig	100.0
Maximum accumulated pressure, psig	121.0
Valve set pressure, psig	110.0
Allowable overpressure, psi	11.0
Relieving pressure, P_1 , psia	135.7

3.6 SIZING FOR GAS OR VAPOR RELIEF

3.6.1 Critical Flow Behavior

3.6.1.1 If a compressible gas is expanded across a nozzle, an orifice, or the end of a pipe, its velocity and specific volume increase with decreasing downstream pressure. For a given set of upstream conditions (using the example of a nozzle), the mass rate of flow through the nozzle will increase until a limiting velocity is reached in the nozzle. It can be shown that the limiting velocity is the velocity of sound in the flowing fluid at that location. The flow rate that corresponds to the limiting velocity is known as the critical flow rate.

3.6.1.2 The absolute pressure ratio of the pressure at the nozzle exit at sonic velocity (P_{cf}) to the inlet pressure (P_1) is called the critical pressure ratio. P_{cf} is known as the critical flow pressure.

3.6.1.3 Under critical flow conditions, the actual pressure at the nozzle exit of the pressure relief device cannot fall below the critical flow pressure even if a much lower pressure exists downstream. At critical flow, the expansion from nozzle pressure to downstream pressure takes place irreversibly with the energy dissipated in turbulence into the surrounding fluid.

3.6.1.4 The critical flow pressure ratio in absolute units may be estimated using the ideal gas relationship in Equation 3.1:

$$\frac{P_{cf}}{P_1} = \left[\frac{2}{k+1} \right]^{k/(k-1)} \quad (3.1)$$

whme

- P_{cf} = critical flow nozzle pressure, in psia,
 P_1 = upstream relieving pressure, in psia,
 k = ratio of specific heats for any ideal gas.

3.6.1.5 The sizing equations for pressure relief devices in vapor or gas service fall into two general categories depending on whether the flow is critical or subcritical. If the pressure downstream of the nozzle is less than, or equal to, the critical flow pressure, P_{cf} , then critical flow will occur, and the procedures in 3.6.2 should be applied. If the downstream pressure exceeds the critical flow pressure, P_{cf} , then subcritical flow will occur, and the procedures in 3.6.3 or 3.6.4 should be applied. (See Table 7 for typical critical flow pressure ratio values.)

3.6.2 Sizing for Critical Flow

3.6.2.1 General

3.6.2.1.1 Pressure relief devices in gas or vapor service that operate at critical flow conditions (see 3.6.1) may be sized using Equations 3.2 – 3.4. Each of the equations may be used to calculate the effective discharge area, A , required to achieve a required flow rate through a pressure relief device. A pressure relief valve that has an effective discharge area equal to or greater than the calculated value of A is then chosen for the application from APT Std 526.

US Customary Units:

$$A = \frac{W}{CK_d P_1 K_b K_c} \sqrt{\frac{TZ}{M}} \quad (3.2)$$

$$A = \frac{V \sqrt{TZM}}{6.32 CK_d P_1 K_b K_c} \quad (3.3)$$

$$A = \frac{V \sqrt{TZG}}{1.175 CK_d P_1 K_b K_c} \quad (3.4)$$

SI Units:

$$A = \frac{13,160 \times W}{CK_d P_1 K_b K_c} \sqrt{\frac{TZ}{M}} \quad (3.2)$$

$$A = \frac{35,250 \times V \sqrt{TZM}}{CK_d P_1 K_b K_c} \quad (3.3)$$

$$A = \frac{189,750 \times V \sqrt{TZG}}{CK_d P_1 K_b K_c} \quad (3.4)$$

where

A = required effective discharge area of the device, in.² [mm²] (see 1.2.2.3).

W = required flow through the device, lb/hr [kg/hr].

C = coefficient determined from an expression of the ratio of the specific heats ($k = C_p/C_v$) of the gas or vapor at inlet relieving conditions. This can be obtained from Figure 32 or Table 8. Where k cannot be determined, it is suggested that a value of C equal to 315 be used. The units for C are

$$\frac{\sqrt{lb_m \times lb_{mole} \times R}}{lb_f \times hr}$$

K_d = effective coefficient of discharge. For preliminary sizing, use the following values:

= 0.975 when a pressure relief valve is installed with or without a rupture disk in combination,

= 0.62 when a pressure relief valve is not installed and sizing is for a rupture disk in accordance with 3.11.1.2.

P_1 = upstream relieving pressure, psia [kPaa]. This is the set pressure plus the allowable overpressure (see 3.5) plus atmospheric pressure.

K_b = capacity correction factor due to back pressure.

This can be obtained from the manufacturer's literature or estimated for preliminary sizing from Figure 30. The back pressure correction factor applies to balanced bellows valves only. For conventional and pilot operated valves, use a value for K_b equal to 1.0 (see 3.3). See 3.6.3 for conventional valve applications with back pressure of a magnitude that will cause subcritical flow.

K_c = combination correction factor for installations with a rupture disk upstream of the pressure relief valve (see 3.11.2).

= 1.0 when a rupture disk is not installed,

= 0.9 when a rupture disk is installed in combination with a pressure relief valve and the combination does not have a published value.

T = relieving temperature of the inlet gas or vapor, R (°F + 460) [K (°C + 273)].

Z = compressibility factor for the deviation of the actual gas from a perfect gas, a ratio evaluated at inlet relieving conditions.

M = molecular weight of the gas or vapor at inlet relieving conditions. Various handbooks carry tables of

Table 7—Properties of Gases

Gas	Molecular Weight	Specific Heat Ratio	Critical Flow	Specific Gravity at 60°F and One Atmosphere	Critical Constants		Condensation	Flammability	References
		($k = C_p/C_v$) at 60°F and One Atmosphere	Pressure Ratio at 60°F and One Atmosphere		Pressure	Temperature	Temperature	Limits (volume percent in air mixture)	
Methane	16.04	1.31	0.54	0.554	673	-116	-259	5.0-15.0	1
Ethane	30.07	1.19	0.57	1.058	718	90	-128	2.9-13.8	1
Ethylene	28.03	1.24	0.57 ^a	0.969	742	50	-155	2.7-34.8	1
Propane	44.09	1.13	0.58	1.522	617	206	-44	2.1-9.5	1
Propylene	47.08	1.15	0.58 ^a	1.453	667	197	-54	2.8-10.8	2, 3
Isobutane	58.12	1.18	0.59 ^a	2.007	529	273	11	1.8-8.4	1
<i>n</i> -Butane	58.12	1.19	0.59	2.007	551	304	31	1.9-8.4	1
1-Butene	56.10	1.11	0.59 ^a	1.937	543	276	21	1.4-9.3	2, 3
Isopentane	72.15	1.08	0.59 ^a	2.491	483	369	82	1.4-8.3	1
<i>n</i> -Pentane	72.15	1.08	0.59 ^a	2.491	490	386	97	1.4-7.8	1
1-Pentene	70.13	1.08	0.59 ^a	2.421	586	377	86	1.4-8.7	1
<i>n</i> -Hexane	86.18	1.06	0.59 ^a	2.973	437	454	156	1.2-7.7	1
Benzene	78.11	1.12	0.58	2.697	714	552	176	1.3-7.9	2, 3
<i>n</i> -Heptane	100.20	1.05	0.60 ^a	3.459	397	513	209	1.0-7.0	1
Toluene	92.13	1.09	0.59	3.181	590	604	231	1.2-7.1	2, 3
<i>n</i> -Octane	114.22	1.05	0.60 ^a	3.944	362	564	258	0.96-	1
<i>n</i> -Nonane	128.23	1.04	0.60 ^a	4.428	552	610	303	0.87-2.9	1
<i>n</i> -Decane	142.28	1.03	0.60 ^a	4.912	304	632	345	0.78-2.6	1
Air	29.96	1.40	0.53	1.000	547	-221	-313	—	2, 3
Ammonia	17.03	1.30	0.53	0.588	1636	270	-28	15.5-27.0	2, 3
Carbon Dioxide	44.01	1.29	0.55	1.519	1071	88	-109	—	2, 3
Hydrogen	2.02	1.41	0.52	0.0696	188	-400	-423	4.0-74.2	2, 3
Hydrogen sulfide	34.08	1.32	0.53	1.176	1306	213	-77	4.3-45.5	2, 3
Sulfur dioxide	64.04	1.27	0.55	2.212	1143	316	14	—	2, 3
Steam	18.01	1.33	0.54	0.622	3206	706	212	—	2, 3

^aEstimated

References:

1. Physical Constants of *Hydrocarbons C₁ to C₁₀*, ASTM Special Technical Publication No. 109A, Philadelphia, Pennsylvania, 1963.
2. *International-Critical Tables*, McGraw-Hill Book Co., Inc., New York, New York.
3. Engineering Data Book, Gas Processors Suppliers Association, Tulsa, Oklahoma, 1977.

molecular weights of materials, but the composition of the flowing gas or vapor is seldom the same as that listed in tables. This value should be obtained from the process data. Table 7 lists values for some common fluids, $\text{lb}_m/\text{lb}_{\text{mole}}$ [$\text{kg}/\text{k}_{\text{mole}}$].

V = required flow through the device, scfm at 14.7 psia and 60°F [Nm^3/min at 0°C and 101.325 kPaa].

G = specific gravity of gas at standard conditions referred to air at standard conditions [normal conditions]. In other words, $G = 1.00$ for air at 14.7 psia and 60°F [101.325 kPaa and 0°C].

3.6.2.1.2 While ideal gas law behavior (with compressibility factor, Z , included) is generally acceptable for the majority of refinery applications, Appendix B should be referred to for unusual situations in which deviation from ideal behavior is significant.

3.6.2.2 Example

3.6.2.2.1 In this example, the following relief requirements are given:

- Required hydrocarbon vapor flow, W , caused by an operational upset, of 53,500 lb/hr [24,260 kg/hr].
- The hydrocarbon vapor is a mixture of butane (C4) and pentane (C5). The molecular weight of vapor, M , is 65.
- Relieving temperature, T , of 627 R (167°F) [1348 K].
- Relief valve set at 75 psig [517 kPa], which is the design pressure of the equipment.
- Back pressure of 14.7 psia (0 psig) [101.3 kPaa (0 kPag)].

3.6.2.2.2 In this example, the following data are derived:

- Permitted accumulation of 10%.
- Relieving pressure, P_1 , of $75 \times 1.1 + 14.7 = 97.2$ psia [670 kPa].

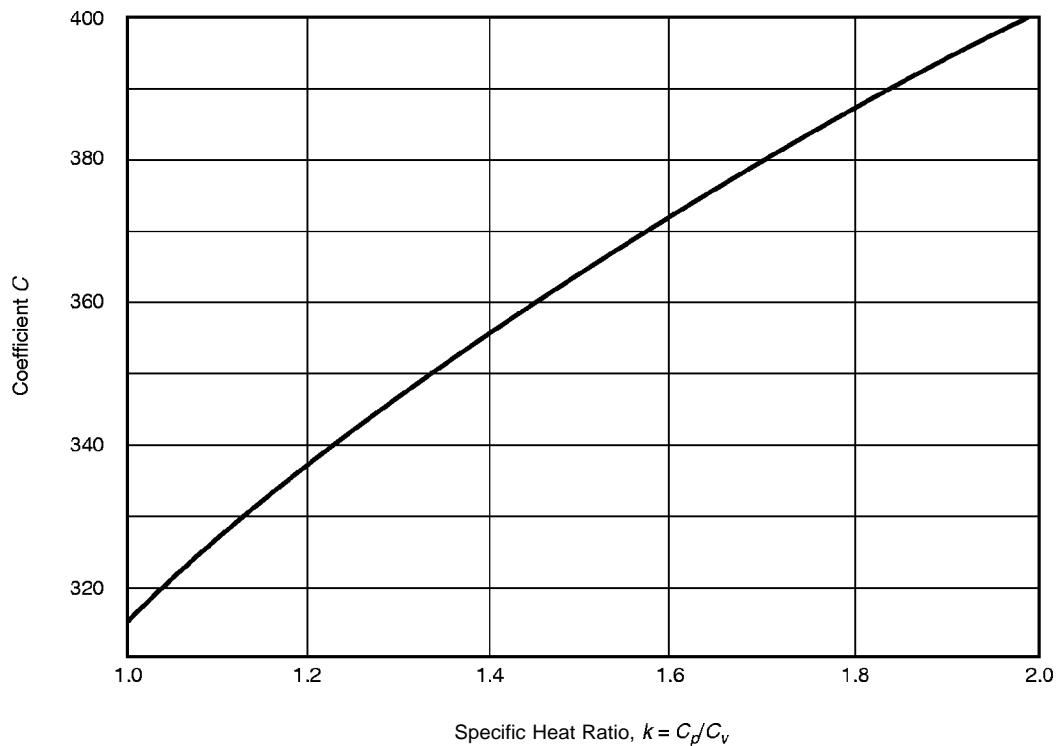

Notes:

- The equation for this curve is $C = 520 \sqrt{k \left(\frac{2}{k+1} \right)^{(k+1)/(k-1)}}$
- The units for the coefficient C are $\sqrt{\text{lb}_m \text{lb}_{\text{mole}}^{-1} \text{R}} / \text{lb}_f \text{hr}$

Figure 32—Curve for Evaluating Coefficient C in the Flow Equation from the Specific Heat Ratio, Assuming Ideal Gas Behavior

c. Calculated compressibility, Z , of 0.84. (If a calculated compressibility is not available, a Z value of 1.0 should be used.)

d. Critical flow pressure (from Table 7) of $97.2 \times 0.59 = 57.3$ psia (42.6 psig) [395 kPaa].

Note: Since the back pressure (0 psig [0 kPaG]) is less than the critical flow pressure (42.6 psig [294 Wag]), the relief valve sizing is based on the critical flow equation (see Equation 3.2 and paragraphs 3.6.1 and 3.6.2).

e. $C_p/C_v = k$ (from Table 7) of 1.09. From Table 8, $C = 326$.

f. Capacity correction due to back pressure, K_b , of 1.0.

g. Capacity Correction for rupture disk, $K_c = 1.0$

3.6.2.2.3 The size of a single pressure relief valve is derived from Equation 3.2 as follows:

$$A = \frac{53,500}{326 \times 0.975 \times 97.2 \times 1.0 \times 1.0} \sqrt{\frac{627 \times 0.84}{65}}$$

$$= 4.93 \text{ in? [3179 mm}^2\text{]}$$

3.6.2.2.4 For selection of the proper orifice size, see API Std 526. API Std 526 provides standard effective orifice areas in terms of letter designations. For this example, a "P" size orifice should be selected since it has an effective orifice area of 6.38 in² (4116 mm²).

3.6.2.2.5 A completed pressure relief valve specification sheet for this example is provided in Figure 33. (A blank specification sheet is provided in Appendix C.)

3.6.3 Sizing for Subcritical Flow: Gas or Vapor

3.6.3.1 Conventional and Pilot-Operated Pressure Relief Valves

When the ratio of back pressure to inlet pressure exceeds the critical pressure ratio P_{cf}/P_1 , the flow through the pressure relief device is subcritical (see 3.6.1). Equations 3.5 – 3.7 may be used to calculate the required effective discharge area for a conventional pressure relief valve that has its spring setting adjusted to compensate for superimposed back pressure. Equations 3.5 – 3.7 may also be used for sizing a pilot-operated relief valve.

US Customary Units:

$$A = \frac{W}{735 \times F_2 K_d K_c} \sqrt{\frac{ZT}{M P_1 (P_1 - P_2)}} \quad (3.5)$$

$$A = \frac{V}{4645 \times F_2 K_d K_c} \sqrt{\frac{ZTM}{P_1 (P_1 - P_2)}} \quad (3.6)$$

$$A = \frac{V}{864 \times F_2 K_d K_c} \sqrt{\frac{ZTG}{P_1 (P_1 - P_2)}} \quad (3.7)$$

SI Units:

$$A = \frac{17.9 \times W}{F_2 K_d K_c} \sqrt{\frac{ZT}{M P_1 (P_1 - P_2)}} \quad (3.5)$$

$$A = \frac{47.95 \times V}{F_2 K_d K_c} \sqrt{\frac{ZTM}{P_1 (P_1 - P_2)}} \quad (3.6)$$

$$A = \frac{258 \times V}{F_2 K_d K_c} \sqrt{\frac{ZTG}{P_1 (P_1 - P_2)}} \quad (3.7)$$

where

A = required effective discharge area of the device, in² [mm²] (see 1.2.2).

W = required flow through the device, lb/hr [kg/hr].

F_2 = coefficient of subcritical flow, see Figure 34 for values or use the following equation:

$$= \sqrt{\left(\frac{k}{k-1}\right) (r)^{2/k} \left[\frac{1-r^{(k-1)/k}}{1-r}\right]}$$

k = ratio of the specific heats.

r = ratio of back pressure to upstream relieving pressure, P_2/P_1 .

K_d = effective coefficient of discharge. For preliminary sizing, use the following values:

= 0.975 when a pressure relief valve is installed with or without a rupture disk in combination,

= 0.62 when a pressure relief valve is not installed and sizing is for a rupture disk in accordance with 3.11.1.2.

K_c = combination correction factor for installations with a rupture disk upstream of the pressure relief valve (see 3.11.2).

= 1.0 when a rupture disk is not installed,

= 0.9 when a rupture disk is installed in combination with a pressure relief valve and the combination does not have a published value.

Z = compressibility factor for the deviation of the actual gas from a perfect gas, evaluated at relieving inlet conditions.

T = relieving temperature of the inlet gas or vapor, R ($^{\circ}\text{F} + 460$) [K ($^{\circ}\text{C} + 273.15$)].

M = molecular weight of the gas or vapor. Various handbooks carry tables of molecular weights of

<p>SPRING-LOADED PRESSURE RELIEF VALVE SPECIFICATION SHEET</p>		Sheet No. _____ Page _____ of _____	
		Requisition No. _____	
		Job No. _____	
		Date _____	
		Revised _____	
By _____			
GENERAL		BASIS OF SELECTION	
1.	Item Number: <i>Example 1</i>	5.	Code: ASME VIII <input checked="" type="checkbox"/> Stamp Required: Yes <input checked="" type="checkbox"/> No <input type="checkbox"/>
2.	Tag Number:		Other <input type="checkbox"/> Specify: _____
3.	Service, Line, or Equipment Number:	6.	Comply with API 526: Yes <input checked="" type="checkbox"/> No <input type="checkbox"/>
4.	Number Required:	7.	Fire <input type="checkbox"/> Other <input checked="" type="checkbox"/> Specify: <i>Control Valve Failure</i>
		8.	Rupture Disk: Yes <input type="checkbox"/> No <input checked="" type="checkbox"/>
VALVE DESIGN		MATERIALS	
9.	Design Type: <i>Safety Relief Valve</i>	17.	Body:
	Conventional <input checked="" type="checkbox"/> Bellows <input type="checkbox"/> Balanced Piston <input type="checkbox"/>	18.	Bonnet:
10.	Nozzle Type: Full <input checked="" type="checkbox"/> Semi <input type="checkbox"/>	19.	Seat (Nozzle): _____ Disk: _____
	Other <input type="checkbox"/> Specify: _____	20.	Resilient Seat:
11.	Bonnet Type: Open <input type="checkbox"/> Closed <input checked="" type="checkbox"/>	21.	Guide:
12.	Seat Type: Metal-to-Metal <input checked="" type="checkbox"/> Resilient <input type="checkbox"/>	22.	Adjusting Ring(s):
13.	Seat Tightness: API 527 <input checked="" type="checkbox"/>	23.	Spring: _____ Washer: _____
	Other <input type="checkbox"/> Specify: _____	24.	Bellows: <i>N/A</i>
CONNECTIONS		25.	Balanced Piston: <i>N/A</i>
14.	Inlet Size: <i>4</i> Rating: <i>150</i> Facing: <i>RF</i>	26.	Comply with NACE MR0175: Yes <input type="checkbox"/> No <input checked="" type="checkbox"/>
15.	Outlet Size: <i>6</i> Rating: <i>150</i> Facing: <i>RF</i>	27.	Other <input type="checkbox"/> Specify: _____
16.	Other <input type="checkbox"/> Specify: _____		
SERVICE CONDITIONS		ACCESSORIES	
33.	Fluid and State: <i>Hydrocarbon Vapor</i>	28.	Cap: Screwed <input type="checkbox"/> Bolted <input checked="" type="checkbox"/>
34.	Required Capacity per Valve and Units: <i>53500 lb/hr</i>	29.	Lifting Lever: Plain <input type="checkbox"/> Packed <input type="checkbox"/> None <input checked="" type="checkbox"/>
35.	Molecular Weight or Specific Gravity: <i>65</i>	30.	Test Gag: Yes <input type="checkbox"/> No <input checked="" type="checkbox"/>
36.	Viscosity at Flowing Temperature and Units: <i>—</i>	31.	Bug Screen: Yes <input type="checkbox"/> No <input checked="" type="checkbox"/>
37.	Operating Pressure and Units: <i>50 psig</i>	32.	Other <input type="checkbox"/> Specify: _____
38.	Set Pressure and Units: <i>75 psig</i>		
39.	Blowdown: Standard <input checked="" type="checkbox"/> Other <input type="checkbox"/>		
40.	Latent Heat of Vaporization and Units:	SIZING AND SELECTION	
41.	Operating Temperature and Units: <i>100°F</i>	49.	Calculated Orifice Area (in square inches): <i>4.93</i>
42.	Relieving Temperature and Units: <i>167°F</i>	50.	Selected Effective Orifice Area (in square inches): <i>6.38</i>
43.	Built-up Back Pressure and Units:	51.	Orifice Designation (letter): <i>P</i>
44.	Superimposed Back Pressure and Units: <i>0</i>	52.	Manufacturer: <i>*</i>
45.	Cold Differential Test Pressure and Units:	53.	Model Number: <i>*</i>
46.	Allowable Overpressure in Percent or Units: <i>10</i>	54.	Vendor Calculations Required: Yes <input checked="" type="checkbox"/> No <input type="checkbox"/>
47.	Compressibility Factor, <i>Z</i> : <i>0.84</i>		
48.	Ratio of Specific Heats: <i>1.09</i>		

Figure 33—Sample of Completed Pressure Relief Valve Specification Sheet

materials, but the composition of the flowing gas or vapor is seldom the same as that listed in the tables. This value should be obtained from the process data. Table 7 lists values for some common fluids, $\text{lb}_m/\text{lb}_{\text{mole}}$ [$\text{kg}/\text{k}_{\text{mole}}$].

P_1 = upstream relieving pressure, psia [kPaa]. This is the set pressure plus the allowable overpressure (see 3.4.5) plus atmospheric pressure.

P_2 = back pressure, psia [kPaa].

V = required flow through the device, scfm at 14.7 psia and 60°F [Nm^3/min at 101.325 kPaa and 0°C].

G = specific gravity of gas at standard conditions referred to air at standard conditions (normal conditions). In other words, $G = 1.00$ for air at 14.7 psia and 60°F (101.325 kPaa and 0°C).

3.6.3.2 Example

3.6.3.2.1 In this example, the following relief requirements are given:

- Required hydrocarbon vapor flow, W , caused by an operational upset, of 53,500 lb/hr (24260 kg/hr).
- The hydrocarbon vapor is a mixture of butane (C4) and pentane (C5). The molecular weight of the vapor, M , is 65.
- Relieving temperature, T , of 627 R (167°F) [348 K].
- Relief valve set at 75 psig [517 kPag], which is the design pressure of the equipment.
- Constant back pressure of 55 psig [379 kPa]. For a conventional valve, the spring setting of the valve should be adjusted according to the amount of constant back pressure obtained. In this example, the Cold Differential Test Pressure, CDTP, would be 20 psig [138 kPa].

3.6.3.2.2 In this example, the following data are derived:

- Permitted accumulation of 10%.
- Relieving pressure, P_1 , of $75 \times 1.1 + 14.7 = 97.2$ psia [670 kPaa].
- Calculated compressibility, Z , of 0.84 (If a calculated compressibility is not available, a value for Z of 1.0 should be used).
- Critical back pressure (from Table 7) of $97.2 \times 0.59 = 57.3$ psia [42.6 psig] (395 kPag [294 Wag]).

Note: Since the back pressure (55 psig [379 kPag]) is greater than the critical back pressure (42.6 psig [395 kPag]), the relief valve sizing is based on the subcritical flow equation (see Equation 3.5 and paragraphs 3.5.1 and 3.5.3).

- Permitted built-up back pressure of $0.10 \times 75 = 7.5$ psi [51.7 kPa]. Note that the actual built-up back pressure should be used if known.
- Total back pressure of $55 + 7.5 = 62.5$ psig [431 Wag].
- $C_p/C_v = k$ (from Table 7) of 1.09.

$$\text{h. } P_2/P_1 = (62.5 + 14.7)/97.2 = 0.794.$$

i. Coefficient of subcritical flow, F_2 , of 0.86 (from Figure 34).

j. Capacity Correction for rupture disk, $K_c = 1.0$

3.6.3.2.3 The size of a single pressure relief valve is derived from Equation 3.5 as follows:

$$A = \frac{53,500}{735 \times 0.86 \times 0.975 \times 1.0} \sqrt{\frac{0.84 \times 627}{65 \times 97.2(97.2 - 77.2)}} \\ = 5.6 \text{ in? } 13610 \text{ mm}^2$$

3.6.3.2.4 For selection of the proper orifice size, see API Std 526. For this example, a ‘‘P’’ size orifice should be selected since it has an effective orifice area of 6.38 in² (4116 mm²).

3.6.3.3 Balanced Pressure Relief Valves

Balanced pressure relief valves should be sized using Equations 3.2 through 3.4 in paragraph 3.6.2.1. The back pressure correction factor in this application accounts for flow velocities that are subcritical as well as the tendency for the disc to drop below full lift (the use of subcritical flow equations are appropriate only where full lift is maintained). The back pressure correction factor, K_b , for this application should be obtained from the manufacturer.

3.6.4 Alternate Sizing Procedure for Conventional and Pilot-Operated Valves in Subcritical Flow

3.6.4.1 General

As an alternative to using the subcritical flow equations given in 3.6.3, the familiar critical flow Equations 3.2–3.4 presented in section 3.6.2 may be used to calculate the required effective discharge area of a conventional or pilot-operated pressure relief valve used in subcritical service. The area obtained using this alternate sizing procedure is identical to the area obtained using the subcritical flow equations. In this alternate method, the capacity correction factor due to back pressure, K_b , is derived by setting the subcritical flow equation (see 3.6.3) equal to the critical flow equation (see 3.6.2) and algebraically solving for K_b . A graphical presentation of the capacity correction factor, K_b , is given in Figure 35. This alternate sizing procedure allows the designer to use the familiar critical flow equation to calculate the same area obtained with the subcritical flow equation provided K_b is obtained from Figure 35 (instead of a K_b value of 1.0 when the critical flow equations of 3.6.2 are used). It should be noted that this method is used only for the sizing of pilot-operated pressure relief valves and conventional (nonbalanced) pressure relief valves that have their spring settings adjusted to compensate for the superimposed back pressure. This method should not be used to size balanced-type valves.

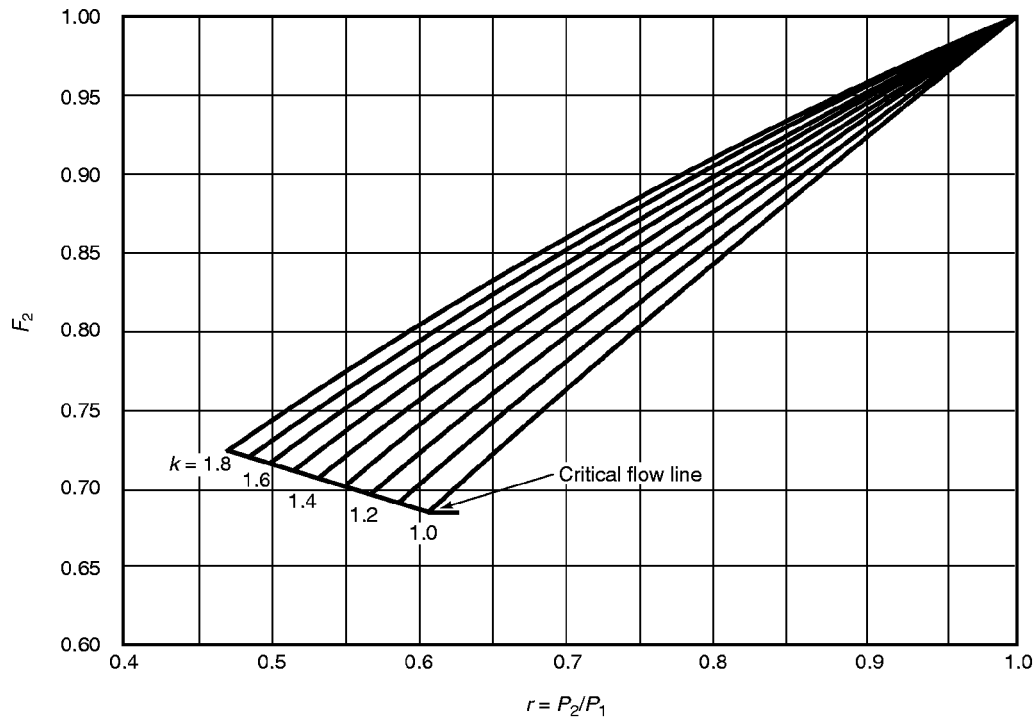
Figure 34—Values of F_2 for Subcritical Flow

3.6.4.2 Example

3.6.4.2.1 In this example, the following relief requirements are given:

- Required hydrocarbon vapor flow, W , caused by an operational upset, of 53,500 lb/hr (24,260 kgs/hr).
- The hydrocarbon vapor is a mixture of butane (C4) and pentane (C5). The molecular weight of the mixture, M , is 65.
- Relieving temperature, T , of 627 R (167°F) [348 K (75°C)].
- Relief valve set at 75 psig [517 Wag], which is the design pressure of the equipment.
- Constant back pressure of 55 psig [379 kPa]. The spring setting of the valve should be adjusted according to the amount of constant back pressure obtained. In this case, the valve spring should be adjusted to open in the shop at a CDTP of 20 psig [138 kPag].

3.6.4.2.2 In this example, the following data are derived:

- Permitted accumulation of 10%.
- Relieving pressure, P_1 , of $75 \times 1.1 + 14.7 = 97.2$ psia [670 kPa].
- Calculated compressibility, Z , of 0.84 (If a calculated compressibility is not available, a value for Z of 1.0 should be used).
- Critical back pressure (from Table 7) of $97.2 \times 0.59 = 57.3$ psia (42.6 psig) [395 kPaa (294 Wag)].

Note: Since the back pressure (55 psig [379 kPag]) is greater than the critical back pressure (42.6 psig [294 kPag]), the sizing of the relief valve is based on subcritical flow. The back pressure correction factor, K_b , should be determined using Figure 35 when the critical flow formulas (see Equations 3.2–3.4) are used.

- Built-up back pressure of $0.10 \times 75 = 7.5$ psi (51.7 kPa).
- Total back pressure of $55 + 7.5 + 14.7 = 77.2$ psia [532 kPaa].
- $C_p/C_v = k$ of 1.09.
- $P_2/P_1 = 77.2/197.2 = 0.794$.
- Back pressure correction factor, K_b , of 0.88 (from Figure 35).
- Coefficient determined from an expression of the ratio of the specific heats of the gas or vapor at inlet relieving conditions, C , of 326 (from Table 8).
- Capacity Correction for rupture disk, $K_c = 1.0$.

3.6.4.2.3 The size of the relief valve is derived from Equation 3.2 as follows:

$$A = \frac{53,500}{326 \times 0.975 \times 97.2 \times 0.88 \times 1.0} \sqrt{\frac{0.84 \times 627}{65}}$$

$$= 5.6 \text{ in.}^2 [3614 \text{ mm}^2]$$

Note that this area requirement is the same as that obtained using the subcritical flow Equation 3.5. See example in 3.6.3.2.

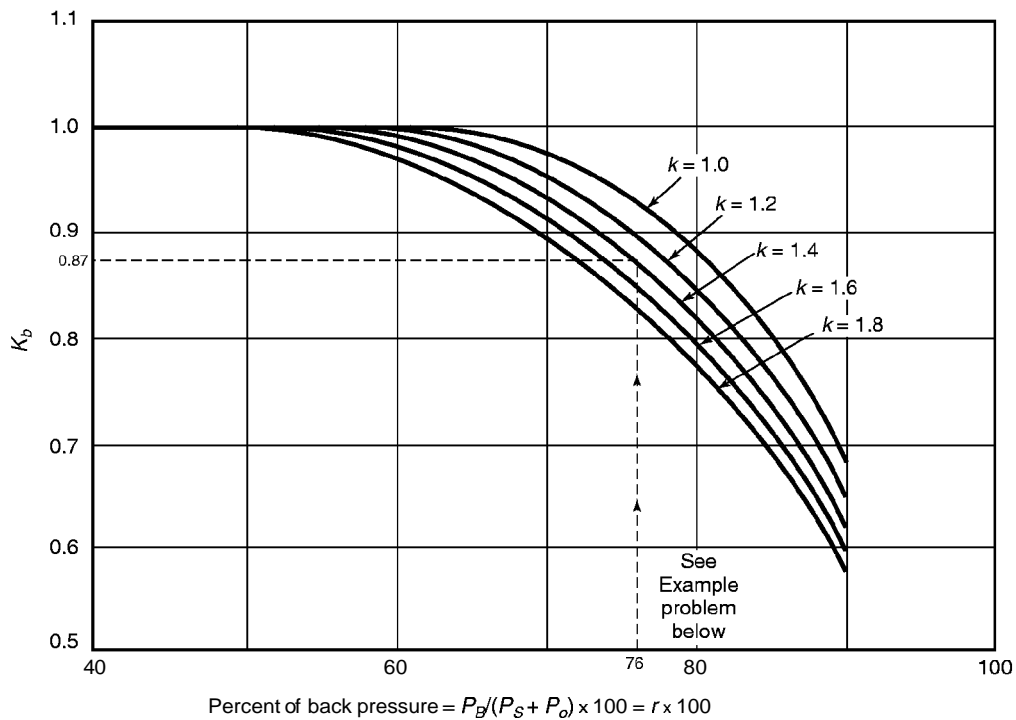

K_b = back pressure correction factor,

P_B = back pressure, in psia,

P_S = set pressure, in psia,

P_O = overpressure, in psi.

Example Problem

Set Pressure (MAWP)	= 100 psig
Overpressure	= 10 psi
Superimposed Back Pressure (constant)	= 70 psig
Spring Set	= 30 psi
Built-up Back Pressure	= 10 psi
Percent Absolute Back Pressure	= $\frac{(70 + 10 + 14.7)}{(100 + 10 + 14.7)} \times 100$
	= 76
K_b (follow dotted line for $C_P/C_V = k = 1.4$)	= 0.87 (from the curve)

Note: This chart is typical and suitable for use only when the make of the valve or the actual critical flow pressure point for the vapor or gas is unknown; otherwise, the valve manufacturer should be consulted for specific data. This correction factor should be used only in the sizing of conventional (nonbalanced) pressure relief valves that have their spring setting adjusted to compensate for the superimposed back pressure. It should not be used to size balanced-type valves.

Figure 35—Constant Back Pressure Correction Factor, K_b , for Conventional Pressure Relief Valves (Vapors and Gases Only)

Table 8—Values of Coefficient C

<i>k</i>	<i>C</i>	<i>k</i>	<i>C</i>	<i>k</i>	<i>C</i>	<i>k</i>	<i>C</i>
1.00	315 ^a	1.30	347	1.60	372	1.90	394
1.01	317	1.31	348	1.61	373	1.91	395
1.02	318	1.32	349	1.62	374	1.92	395
1.03	319	1.33	350	1.63	375	1.93	396
1.04	320	1.34	351	1.64	376	1.94	397
1.05	321	1.35	352	1.65	376	1.95	397
1.06	322	1.36	353	1.66	377	1.96	398
1.07	323	1.37	353	1.67	378	1.97	398
1.08	325	1.38	354	1.68	379	1.98	399
1.09	326	1.39	355	1.69	379	1.99	400
1.10	327	1.40	356	1.70	380	2.00	400
1.11	328	1.41	357	1.71	381	—	—
1.12	329	1.42	358	1.72	382	—	—
1.13	330	1.43	359	1.73	382	—	—
1.14	331	1.44	360	1.74	383	—	—
1.15	332	1.45	360	1.75	384	—	—
1.16	333	1.46	361	1.76	384	—	—
1.17	334	1.47	362	1.77	385	—	—
1.18	335	1.48	363	1.78	386	—	—
1.19	336	1.49	364	1.79	386	—	—
1.20	337	1.50	365	1.80	387	—	—
1.21	338	1.51	365	1.81	388	—	—
1.22	339	1.52	366	1.82	389	—	—
1.23	340	1.53	367	1.83	389	—	—
1.24	341	1.54	368	1.84	390	—	—
1.25	342	1.55	369	1.85	391	—	—
1.26	343	1.56	369	1.86	391	—	—
1.27	344	1.57	370	1.87	392	—	—
1.28	345	1.58	371	1.88	393	—	—
1.29	346	1.59	372	1.89	393	—	—
1.30	347	1.60	373	1.90	394	—	—

^aThe limit of *C*, as *k* approaches 1.00, is 315.

3.7 SIZING FOR STEAM RELIEF

3.7.1 General

Pressure relief devices in steam service that operate at critical flow conditions may be sized using Equation 3.8.

US Customary Units

$$A = \frac{W}{51.5 \times P_1 K_d K_b K_c K_N K_{SH}} \quad (3.8)$$

SI Units

$$A = \frac{190.4 \times W}{P_1 K_d K_b K_c K_N K_{SH}} \quad (3.8)$$

where

A = required effective discharge area, in.² [mm²] (see 1.2.2).

W = required flow rate, lb/hr (kg/hr).

*P*₁ = upstream relieving pressure, psia (kPaa). This is the set pressure plus the allowable overpressure (see 3.4) plus the atmospheric pressure.

*K*_{*d*} = effective coefficient of discharge. For preliminary sizing, use the following values:

= 0.975 when a pressure relief valve is installed with or without a rupture disk in combination,

= 0.62 when a pressure relief valve is not installed and sizing is for a rupture disk in accordance with 3.11.1.2.

K_b = capacity correction factor due to back pressure.

This can be obtained from the manufacturer's literature or estimated from Figure 30. The back pressure correction factor applies to balanced bellows valves only. For conventional valves, use a value for K_b equal to 1.0 (see 3.3). See 3.6.3 for conventional valve applications that involve superimposed back pressure of a magnitude that will cause sub-critical flow.

K_c = combination correction factor for installations with a rupture disk upstream of the pressure relief valve (see 3.11.2),

= 1.0 when a rupture disk is not installed,

= 0.9 when a rupture disk is installed in combination with a pressure relief valve and the combination does not have a published value.

K_N = correction factor for Napier equation (see Reference 4.1),

= 1 where $P_1 \leq 1500$ psia (10,339 kPaa),

$$= \frac{0.1906 \times P_1 - 1000}{0.2292 \times P_1 - 1061} \quad (\text{US Customary Units})$$

$$= \frac{0.02764 \times P_1 - 1000}{0.03324 \times P_1 - 1061} \quad (\text{SI Units})$$

where $P_1 > 1500$ psia (10,339 kPaa) and ≤ 3200 psia (22,057 kPaa).

K_{SH} = superheat steam correction factor. This can be obtained from Table 9. For saturated steam at any pressure, $K_{SH} = 1.0$.

3.7.2 Example

3.7.2.1 In this example, the following relief requirement is given:

W = saturated steam at 153,500 lb/hr (69,615 kgs/hr) at 1600 psig (11,032 kPag) set pressure with 10% accumulation. Note that the set pressure is equal to the design pressure in this example.

Table 9—Superheat Correction Factors, K_{SH}

Set Pressure (psig)	Temperature (degrees Fahrenheit)									
	300	400	500	600	700	800	900	1000	1100	1200
15	1.00	0.98	0.93	0.88	0.84	0.80	0.77	0.74	0.72	0.70
20	1.00	0.98	0.93	0.88	0.84	0.80	0.77	0.74	0.72	0.70
40	1.00	0.99	0.93	0.88	0.84	0.81	0.77	0.74	0.72	0.70
60	1.00	0.99	0.93	0.88	0.84	0.81	0.77	0.75	0.72	0.70
80	1.00	0.99	0.93	0.88	0.84	0.81	0.77	0.75	0.72	0.70
100	1.00	0.99	0.94	0.89	0.84	0.81	0.77	0.75	0.72	0.70
120	1.00	0.99	0.94	0.89	0.84	0.81	0.78	0.75	0.72	0.70
140	1.00	0.99	0.94	0.89	0.85	0.81	0.78	0.75	0.72	0.70
160	1.00	0.99	0.94	0.89	0.85	0.81	0.78	0.75	0.72	0.70
180	1.00	0.99	0.94	0.89	0.85	0.81	0.78	0.75	0.72	0.70
200	1.00	0.99	0.95	0.89	0.85	0.81	0.78	0.75	0.72	0.70
220	1.00	0.99	0.95	0.89	0.85	0.81	0.78	0.75	0.72	0.70
240	—	1.00	0.95	0.90	0.85	0.81	0.78	0.75	0.72	0.70
260	—	1.00	0.95	0.90	0.85	0.81	0.78	0.75	0.72	0.70
280	—	1.00	0.96	0.90	0.85	0.81	0.78	0.75	0.72	0.70
300	—	1.00	0.96	0.90	0.85	0.81	0.78	0.75	0.72	0.70
350	—	1.00	0.96	0.90	0.86	0.82	0.78	0.75	0.72	0.70
400	—	1.00	0.96	0.91	0.86	0.82	0.78	0.75	0.72	0.70
500	—	1.00	0.96	0.92	0.86	0.82	0.78	0.75	0.73	0.70
600	—	1.00	0.97	0.92	0.87	0.82	0.79	0.75	0.73	0.70
800	—	—	1.00	0.95	0.88	0.83	0.79	0.76	0.73	0.70
1000	—	—	1.00	0.96	0.89	0.84	0.78	0.76	0.73	0.71
1250	—	—	1.00	0.97	0.91	0.85	0.80	0.77	0.74	0.71
1500	—	—	—	1.00	0.93	0.86	0.81	0.77	0.74	0.71
1750	—	—	—	1.00	0.94	0.86	0.81	0.77	0.73	0.70
2000	—	—	—	1.00	0.95	0.86	0.80	0.76	0.72	0.69
2500	—	—	—	1.00	0.95	0.85	0.78	0.73	0.69	0.66
3000	—	—	—	—	1.00	0.82	0.74	0.69	0.65	0.62

3.7.2.2 In this example, the following data are derived:

- Relieving pressure, P_1 , of $1600 \times 1.1 + 14.7 = 1774.7$ psia (12,236 kPa).
- Effective coefficient of discharge, K_d , of 0.975.
- Back pressure correction factor, K_b , of 1.0 for conventional valve discharging to atmosphere.
- Capacity Correction for rupture disk, $K_c = 1.0$, since there is no rupture disk.
- Correction factor for the Napier equation, K_N , of $[0.1906(1774.7) - 1000]/[0.2293(1774.7) - 10611] = 1.01$.
- Supercat steam correction factor, K_{SH} , of 1.0.

3.7.2.3 The size of the relief valve is derived from Equation 3.8 as follows:

$$A = \frac{153,500}{51.5(1774.7)(0.975)(1.0)(1.0)(1.01)(1.0)}$$

$$= 1.705 \text{ in.}^2 [1100 \text{ mm}^2]$$

3.7.2.4 For selection of the proper orifice size, see API Std 526. For this example, a “K” size orifice should be selected since it has an effective orifice area of 1.838 in.^2 (1186 mm^2).

3.8 SIZING FOR LIQUID RELIEF: PRESSURE RELIEF VALVES REQUIRING CAPACITY CERTIFICATION

3.8.1 General

3.8.1.1 Section VIII, Division I, of the ASME Code requires that capacity certification be obtained for pressure relief valves designed for liquid service. The procedure for obtaining capacity certification includes testing to determine the rated coefficient of discharge for the liquid relief valves at 10% overpressure.

3.8.1.2 Valves in liquid service that are designed in accordance with the ASME Code which require a capacity certification may be initially sized using Equation 3.9.

US Customary Units

$$A = \frac{Q}{38K_dK_wK_cK_v} \sqrt{\frac{G}{p_1 - p_2}} \quad (3.9)$$

SI Units

$$A = \frac{11.78 \times Q}{K_dK_wK_cK_v} \sqrt{\frac{G}{p_1 - p_2}} \quad (3.9)$$

where

A = required effective discharge area, in.^2 (mm^2).

Q = flow rate, U.S. gpm (liters/min).

K_d = rated coefficient of discharge that should be obtained from the valve manufacturer. For a preliminary sizing, an effective discharge coefficient can be used as follows:

= 0.65 when a pressure relief valve is installed with or without a rupture disk in combination,

= 0.62 when a pressure relief valve is not installed and sizing is for a rupture disk in accordance with 3.11.1.2.

K_w = correction factor due to back pressure. If the back pressure is atmospheric, use a value for K_w of 1.0. Balanced bellows valves in back pressure service will require the correction factor determined from Figure 31. Conventional and pilot operated valves require no special correction. See 3.3.

K_c = combination correction factor for installations with a rupture disk upstream of the pressure relief valve (see 3.11.2),

= 1.0 when a rupture disk is not installed,

= 0.9 when a rupture disk is installed in combination with a pressure relief valve and the combination does not have a published value.

K_v = correction factor due to viscosity as determined from Figure 36 or from the following equation:

$$= \left(0.9935 + \frac{2.878}{R^{0.5}} + \frac{342.75}{R^{1.5}} \right)^{-1.0}$$

G = specific gravity of the liquid at the flowing temperature referred to water at standard conditions.

p_1 = upstream relieving pressure, psig (kPag). This is the set pressure plus allowable overpressure.

p_2 = back pressure, psig (Wag).

3.8.1.3 When a relief valve is sized for viscous liquid service, it should first be sized as if it were for a nonviscous type application (i.e., $K_v = 1.0$) so that a preliminary required discharge area, A , can be obtained from Equation 3.9. From API Std 526 standard orifice sizes, the next orifice size larger than A should be used in determining the Reynold's Number, R , from either of the following relationships:

US Customary Units

$$R = \frac{Q(2800 \times G)}{\mu\sqrt{A}} \quad (3.10)$$

or

$$R = \frac{12,700 \times Q}{U\sqrt{A}} \quad (3.11)$$

SI Units

$$R = \frac{Q(18,800 \times G)}{\mu\sqrt{A}} \quad (3.10)$$

or

$$R = \frac{85,220 \times Q}{U\sqrt{A}} \quad (3.11)$$

where

R = Reynold's Number.

Q = flow rate at the flowing temperature, U.S. gpm (liters/min).

G = specific gravity of the liquid at the flowing temperature referred to water at standard conditions.

 μ = absolute viscosity at the flowing temperature, centipoise.A = effective discharge area, in.² (mm²) (from API Std 526 standard orifice areas).

U = viscosity at the flowing temperature, in Saybolt Universal seconds, SSU.

Note: Equation 3.11 is not recommended for viscosities less than 100 Saybolt Universal seconds.

3.8.1.4 After the Reynold's Number, R, is determined, the factor K_v is obtained from Figure 36. K_v is then applied in Equation 3.9 to correct the preliminary required discharge area. If the corrected area exceeds the chosen standard orifice area, the above calculations should be repeated using the next larger standard orifice size.

3.8.2 Example

3.8.2.1 In this example, the following relief requirements are given:

- Required crude oil flow caused by blocked discharge, Q, of 1800 gpm (6814 liters/min).
- The specific gravity, G, of the crude oil is 0.90. The viscosity of the crude oil at the flowing temperature is 2000 Saybolt Universal seconds.

- Relief valve set at 250 psig (1724 kPag), which is the design pressure of the equipment.
- Back pressure is variable from 0 to 50 psig (345 Wag).

3.8.2.2 In this example, the following data are derived:

- Overpressure of 10%.
- Relieving pressure, P_1 , of $1.10 \times 250 = 275$ psig (1896 kPag).
- Back pressure of $(50/250) \times 100 = 20\%$.
- A balanced bellows valve should be selected, since the back pressure is variable. From Figure 31, the back pressure capacity correction factor, $K_p = 0.97$.
- The effective coefficient of discharge for preliminary sizing, $K_d = 0.65$.

3.8.2.3 Sizing first for no viscosity correction ($K_v = 1.0$), the size of the relief valve is derived from Equation 3.9 as follows:

$$A_R = \frac{1800}{38.0 \times 0.65 \times 0.97 \times 1.0 \times 1.0} \sqrt{\frac{0.90}{275 - 50}}$$

$$= 4.752 \text{ in.}^2 \text{ (3066 mm}^2\text{)}$$

where A_R is the required area of the relief valve without any viscosity correction. An area of 6.38 in.² [4116 mm²] ("P" orifice) should be selected from API Std 526.

3.8.2.4 The Reynold's Number, R, is then calculated using Equation 3.11.

$$R = \frac{12,700 \times 1800}{2000 \sqrt{6.38}} = 4525$$

3.8.2.5 From Figure 36, the viscosity correction factor is determined, $K_v = 0.964$.

Therefore:

$$A = \frac{A_R}{K_v} = \frac{4.752}{0.964}$$

$$= 4.930 \text{ in.}^2 \text{ (3180 mm}^2\text{)}$$

3.8.2.6 For this example problem, select an "P" orifice pressure relief valve (6.38 in.² [4116 mm²]), that is, a 4P6 pressure relief valve.

3.9 SIZING FOR LIQUID RELIEF: PRESSURE RELIEF VALVES NOT REQUIRING CAPACITY CERTIFICATION

3.9.1 Before the ASME Code incorporated requirements for capacity certification, valves were generally sized for

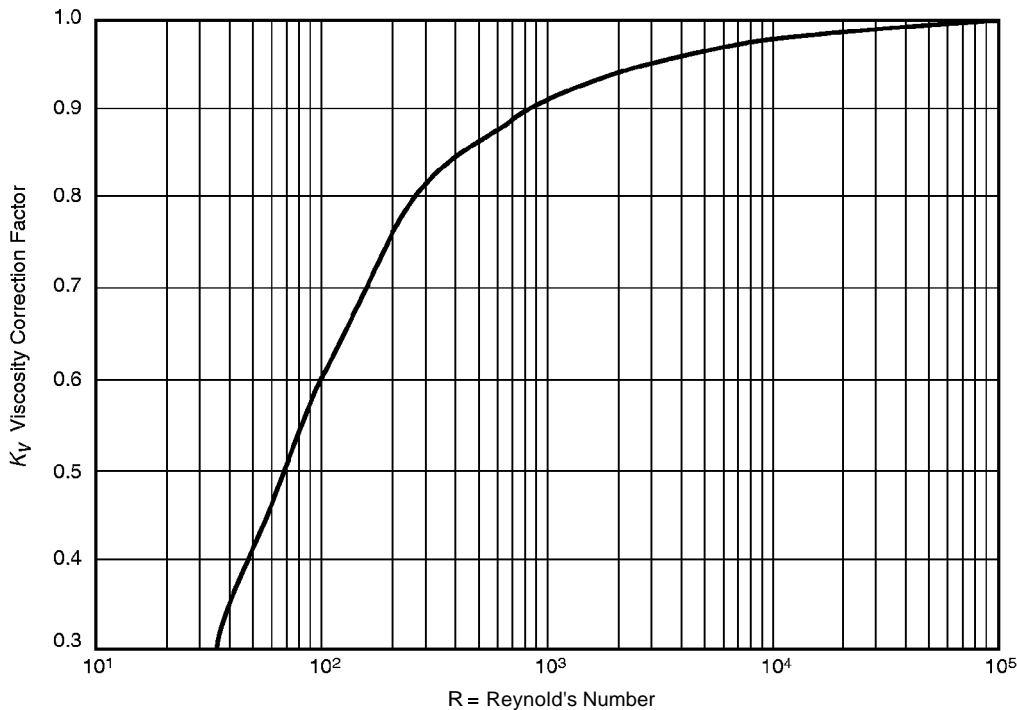

Figure 36—Capacity Correction Factor, K_v , Due to Viscosity

liquid service using Equation 3.12. This method assumes an effective coefficient of discharge, $K_d = 0.62$, and 25% overpressure. An additional capacity correction factor, K_p , is needed for relieving pressures other than 25% overpressure, see Figure 37. This sizing method may be used where capacity certification is not required or is unknown.

3.9.2 This method will typically result in an oversized design where a liquid valve is used for an application with 10% overpressure (see 2.2.1.2). A K_p correction factor of 0.6 is used (see Figure 37) for this situation.

US Customary Units

$$A = \frac{Q}{38K_dK_wK_cK_vK_p} \sqrt{\frac{G}{1.25p - p_b}} \quad (3.12)$$

SI Units

$$A = \frac{11.78 \times Q}{K_dK_wK_cK_vK_p} \sqrt{\frac{G}{1.25p - p_b}} \quad (3.12)$$

where

A = required effective discharge area, in.² (mm²).

Q = flow rate, U.S. gpm [liters/min].

K_d = rated coefficient of discharge that should be obtained from the valve manufacturer. For a preliminary sizing estimation, an effective discharge coefficient of 0.62 can be used.

K_w = correction factor due to back pressure. If back pressure is atmospheric, $K_w = 1$. Balanced bellows valves in back pressure service will require the correction factor determined from Figure 31. Conventional valves require no special correction. See 3.3.

K_c = combination correction factor for installations with a rupture disk upstream of the pressure relief valve (See 3.11.2). Use a value for K_c equal to 1.0 when a rupture disk does not exist.

K_v = correction factor due to viscosity as determined from Figure 36 or from the following equation:

$$= \left(0.9935 + \frac{2.878}{R^{0.5}} + \frac{342.75}{R^{1.5}} \right)^{-1.0}$$

K_p = correction factor due to overpressure. At 25% overpressure, $K_p = 1.0$. For overpressures other than 25%, K_p is determined from Figure 37.

G = specific gravity of the liquid at the flowing temperature referred to water at standard conditions.

p = set pressure, psig [Wag].

p_b = total back pressure, psig [Wag].

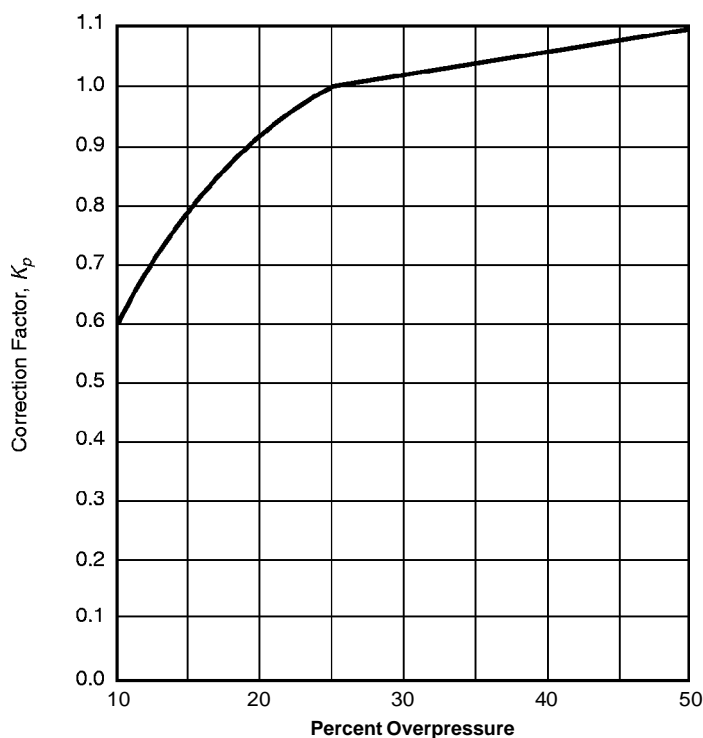

Note: The curve above shows that up to and including 25% overpressure, capacity is affected by the change in lift, the change in the orifice discharge coefficient, and the change in overpressure. Above 25%, capacity is affected only by the change in overpressure. Noncertified valves operating at low overpressure tend to chatter; therefore, overpressures of less than 10% should be avoided.

Figure 37—Capacity Correction Factors Due to Overpressure for Noncertified Pressure Relief Valves in Liquid Service

3.10 SIZING FOR TWO-PHASE LIQUID/VAPOR RELIEF

3.10.1 A pressure relief device handling a liquid at vapor liquid equilibrium or a mixed phase fluid will produce flashing with vapor generation as the fluid moves through the device. The vapor generation must be taken into account, since it may reduce the effective mass flow capacity of the device.

3.10.2 A recommended method for sizing pressure relief devices in two-phase service is presented in Appendix D. The user should be aware that there are currently no pressure relief devices with certified capacities for two-phase flow since there are no testing methods for certification.

3.10.3 A balanced or pilot operated pressure relief valve may be necessary when the increase in back pressure due to flashing or two-phase flow conditions is excessive or cannot be adequately predicted. The actual flowrate through a device can be many times higher if equilibrium is not achieved in the nozzle.

3.10.4 For information about saturated water, see Section VIII, Appendix 11, of the ASME Code.

3.10.5 The designer should also investigate the effect of any autorefrigeration that may arise from the flashing of liquid. Materials of construction must be adequate for the outlet temperatures involved; in addition, the installation must preclude the possibility of flow blockage occurring from hydrate or possibly solid formation.

3.11 SIZING FOR RUPTURE DISK DEVICES

3.11.1 Rupture Disk Devices Used Independently

3.11.1.1 General

Rupture disk devices may be used as the primary relief device for gas, vapor, liquid or multiphase service. The rupture disk size, when used as the sole relieving device shall be determined as specified in 3.11.1.2 or 3.11.1.3. Section 3.11.1.2 may only be used when a rupture disk device discharges directly to the atmosphere, is installed within 8 pipe

diameters from the vessel nozzle entry, has a length of discharge not greater than 5 pipe diameters, and has nominal diameters of the inlet and outlet discharge piping equal to or greater than the nominal pipe size of the device. Section 3.11.1.3 applies in all other cases.

3.11.1.2 Rupture Disk Sizing Using Coefficient of Discharge Method ($K_d = 0.62$)

3.11.1.2.1 The required discharge area, A in square inches, can be calculated using the appropriate equation for the flowing fluid (see Equations 3.2 – 3.7 for gas or vapor, Equation 3.8 for steam, and Equation 3.9 for liquid). When using these equations, a coefficient of discharge, K_d , of 0.62 should be used (see 3.11.1.1 for limitations on using this method).

3.11.1.2.2 The nominal size of the rupture disk device selected shall have a minimum net flow area equal to or greater than the required calculated discharge area. Consult the manufacturer for the minimum net flow area of the rupture disk device.

3.11.1.3 Rupture Disk Sizing Using Flow Resistance Method

3.11.1.3.1 The calculated size of a pressure relief system containing a rupture disk device may also be determined by analyzing the total system resistance to flow. This analysis shall take into consideration the flow resistance of the rupture disk device, piping and other piping components, entrance and exit losses, elbows, tees, reducers, and valves. The calculation shall be made using accepted engineering practices for determining fluid flow through piping systems. The calculated relieving capacity shall be multiplied by a factor of 0.90 or less to allow for uncertainties inherent with this method. In these calculations, flow resistance for rupture disk devices can be obtained from the manufacturer. The flow resistance is expressed in terms of velocity head loss (K_R). ASME Code certified values should be used where available.

3.11.1.3.2 An example of the flow resistance method is provided in Appendix E.

3.11.2 Rupture Disk Devices Used in Combination with Pressure Relief Valves

The capacity of a rupture disk device in combination with a pressure relief valve, where the rupture disk device is located at the valve inlet may be determined by multiplying the ASME stamped valve capacity by the combination capacity factor, K_C . K_C values are published by the National Board of Boiler and Pressure Vessel Inspectors for specific disk/valve combinations. When a disk/valve combination does not have a published K_C then a K_C value of 0.90 shall be used provided the flow area is equal to or greater than the inlet of the pressure relief valve.

4 References

- 4.1** Thompson and O. E. Buxton, Jr., "Maximum Isentropic Flow of Dry Saturated Steam Through Pressure Relief Valves," *Transactions of the ASME Journal of Pressure Vessel Technology*, May 1979, Volume 101, pp. 113–117.
- 4.2** J. Heller, "Safety Relief Valve Sizing: API Versus CGA Requirements Plus a New Concept for Tank Cars," 1983 *Proceedings—Refining Department*, Volume 62, American Petroleum Institute, Washington, D.C., pp. 123–135.
- 4.3** J.O. Francis and W.E. Shackelton, "A Calculation of Relieving Requirements in the Critical Region," 1985 *Proceedings—Refining Department*, Volume 64, American Petroleum Institute, Washington, D.C., pp. 179–182.
- 4.4** H.G. Fisher, "DIERS Research Program on Emergency Relief Systems," *Chemical Engineering Progress*, August 1985, pp. 33–36.
- 4.5** H.K. Fausle and J.C. Leung, "New Experimental Technique for Characterizing Runaway Chemical Reactions," *Chemical Engineering Progress*, August 1985, pp. 39–46.
- 4.6** M.A. Grolmes and J.C. Leung, "Code Method for Evaluating Integrated Relief Phenomena," *Chemical Engineering Progress*, August 1985, pp. 47–52.
- 4.7** H.K. Fauske, "Emergency Relief System Design," *Chemical Engineering Progress*, August 1985, pp. 53–56.
- 4.8** M.A. Grolmes, J.C. Leung, and H. K. Fauske, "Large-Scale Experiments of Emergency Relief Systems," *Chemical Engineering Progress*, August 1985, pp. 57–62.
- 4.9** Publication 999 (English Edition), *Technical Data Book—Petroleum Refining*, American Petroleum Institute, Washington, D.C.
- 4.10** O. Cox, Jr. and M.L. Weirick, "Sizing Safety Valve Inlet Lines," *Chemical Engineering Progress*, November 1980.
- 4.11** B.A. Van Boskirk, "Sensitivity of Relief Valves to Inlet and Outlet Line Lengths," *Chemical Engineering*, August 1982.
- 4.12** J.C. Leung, "The Omega Method for Discharge Rate Evaluation," *International Symposium on Runaway Reactions and Pressure Relief Design*, American Institute of Chemical Engineers, New York, pp. 367–393, 1995, ISBN No. 0-8169-0676-9.
- 4.13** M.A. Grolmes and J.C. Leung, "A Generalized Correlation for Flashing Choked Flow of Initially Subcooled Liquids," *AIChE Journal*, Volume 34, April 1988, pp. 688–691.

APPENDIX A—RUPTURE DISK DEVICE SPECIFICATION SHEET

A line-by-line description of the information to be provided on the rupture disk device specification sheet is provided in this appendix, followed by a typical blank specification sheet.

Line No.	Instruction
1.	Item Number: Sequential number from requisition.
2.	Tag Number: Number assigned to rupture disk which identifies rupture disk location
3.	Service, Line, or Equipment No.: Number identifying the service, line, or equipment in which the rupture disk is installed.
4.	Applicable Codes or Standards: Specify applicable codes or standards (e.g. ASME, API, ISO, etc.) for sizing, marking, burst tolerance, testing, etc.
5.	Vessel or Piping Maximum Allowable Working Pressure: This pressure is defined in the ASME Code and is specified by the user for the vessel or piping to be protected. This pressure may also be used to evaluate proper sizing and marking.
6.	Fluid: The process media is used by the user to define compatible materials for rupture disks and holders.
7.	Fluid State (initiating rupture): Gas (vapor) or liquid. Some disks are designed to burst with vapor only. The user should consult the rupture disk manufacturer for information about liquid service applications.
8.	Fluid State (relieving condition): Gas (vapor), liquid, or multiphase flow. Users need this information to calculate flow rates and size the rupture disk device.
9.	Required Relieving Capacity: User to document the required relieving capacity and units for the disk specified. See 3.11 for sizing of rupture disk devices.
10.	Molecular Weight or Specific Gravity: (at relieving temperature) Needed to size relieving system components.
11.	Viscosity: (at relieving temperature) Needed to size relieving system components if viscous fluid. User to specify units.
12.	Compressibility Factor (Z): This factor is used as a constant in disk sizing using the coefficient of discharge method.
13.	Specific Heat Ratio: This constant is used in disk sizing calculations.
14.	Normal Maximum Operating Pressure: The maximum pressure at which the system normally operates. This pressure is used to calculate the operating ratio.
15.	Normal Maximum Operating Temperature: The maximum temperature at which the system normally operates. This temperature is used to evaluate disk type, material, and performance.
16.	Pressure Fluctuations (static, cyclic, pulsating): Specify cyclic or pulsating service when applicable. Cycling service is considered as a large amplitude and low frequency. Cyclic service with vacuum cycles must be indicated. Pulsating service is considered as small amplitude and high frequency. For certain types of rupture disks, the operating ratio affects the service life in cyclic applications.
17.	Superimposed Back Pressure: See 1.2.3.3k for definition. A rupture disk is a differential pressure device, therefore, this pressure needs to be considered when specifying burst pressure. Additionally, superimposed backpressure is used to determine disk type and construction. (e.g. vacuum/backpressure supports). For disks vented to atmosphere, the superimposed back pressure is atmospheric pressure and it is constant. See 2.3.6.1 for a discussion on the effects of superimposed back pressure on rupture disk selection.
18.	Built-up Back Pressure: See 1.2.3.3j for definition. This pressure is used to determine system back pressure.
19.	Back Pressure: See 1.2.3.3i for definition.

Line No.	Instruction
20.	Inlet Vacuum Conditions: Inlet vacuum conditions are used to determine rupture disk type and construction (e.g., vacuum supports). Select and document vacuum units carefully, absolute units have positive values and gage units have negative values.
21.	Outlet Vacuum Conditions: A rupture disk is a differential pressure device, therefore, outlet vacuum needs to be considered when specifying the burst pressure.
22.	Disk Located Upstream of Pressure Relief Valve (yes/no): This information is needed to verify proper selection (e.g., 3% rule) of non-fragmenting disks.
23.	Disk Located Downstream of Pressure Relief Valve (yes/no): This information is needed by the user to verify installation and sizing requirements for this application.
24.	Nonfragmenting Disk (yes/no): See 1.2.1.4c for definition. User must specify nonfragmenting requirement to the manufacturer.
25.	Nominal Pipe Size: This information is used to identify the nominal size of the mating fittings.
26.	Applicable Flange Standard & Class: This information is used to identify pressure ratings and dimensions of holders.
27.	Flange Facing (inlet/outlet): Used to identify the mating flange facing, e.g., RF, FF
28.	Piping Connection (schedule/bore): This information is used to evaluate flow area and proper selection of holderless disks.
29.	Holder Tag No.: Number assigned to rupture disk holder which identifies holder location.
30.	Nominal Holder Size: Specify nominal holder size. In some cases nominal holder size may be larger than the relief piping to obtain lower burst pressures.
31.	Design Type: Specify holder type, such as insert or full bolting. Holder selection may be based on ease of installation and maintenance or mating connections. Full bolting holders may reduce the seal flow to flange studs in a fire.
32.	Model Designator: When known, specify the applicable manufacturer's model number, name, or designator.
33.	Quantity Required: Specify quantity of holders required. Preventive maintenance and spares should be considered.
34.	Holder Material & Coatings (inlet): User should select an inlet material compatible with process fluids. Coatings and linings are sometimes used to enhance corrosion resistance or reduce product buildup.
35.	Holder Material & Coatings (outlet): Outlet holder material may be different from inlet holder material and should be selected based on frequency and duration of exposure to process and downstream fluids.
36.	Gauge Tap (yes/no) and Size (NPT) (outlet): Gauge taps in holder outlets are primarily used to vent and/or monitor the cavity between a rupture disk and a downstream pressure relief valve. See 2.3.2.2.
37.	Studs and Nuts (yes/no) and Material: Specify if studs and nuts are to be supplied with the rupture disk holder and if so what materials (e.g. alloy or stainless steel).
38.	Jackscrews (yes/no): Indicate if jackscrews are required. Jackscrews are used to separate mating flanges to facilitate installation and maintenance of holders.
39.	Telltale Assembly (yes/no) and Material: Telltale assemblies typically consist of a pressure gauge, excess flow valve, and connecting fittings. These assemblies are installed in holder outlets that are located upstream of pressure relief valves. These devices provide venting and monitoring of the cavity between the disk and valve as specified in 2.3.2.2. If other monitoring devices are required, indicate here.
40.	Other: Space provided for specifying other accessories.
41.	Nominal Disk Size: Specify nominal disk size. In some cases the nominal disk size may be larger than the relief piping to obtain lower burst pressures.
42.	Disk Type: Identify preference, if any, for forward-acting, reverse-acting, or graphite.

Line No.	Instruction
43.	<i>Model Designator:</i> When known, specify the applicable manufacturer's model number, name, or designator.
44.	<i>Quantity Required:</i> Specify quantity of disks required. Startup, preventive maintenance, and spares should be considered.
45.	<i>Manufacturing Range:</i> User to specify the desired manufacturing range. The manufacturing range must always be evaluated before the specified burst pressure is determined to ensure that the marked burst pressure will be within applicable ASME Code pressure limits. Manufacturing ranges generally depend on (a) the specified burst pressure level, (b) the rupture disk design type, and (c) the rupture disk manufacturer. Manufacturing ranges are expressed as (a) plus or minus a percentage of the specified pressure, (b) plus or minus pressure units, or (c) zero percent or no manufacturing range. See 1.2.3.3h for definition.
46.	<i>Specified Burst Temperature:</i> User to specify the temperature at which the disk is to be rated and marked.
47.	<i>Specified Burst Pressure:</i> A pressure specified by the user taking into consideration manufacturing range, burst tolerance, superimposed back pressure and operating pressure.
48.	<i>Maximum Marked Burst Pressure:</i> This pressure is calculated by adding the positive manufacturing range to the specified burst pressure. The maximum marked burst pressure is then verified to meet the vessel or piping protection requirements for single, multiple, fire, or redundant applications.
49.	<i>Minimum Marked Burst Pressure:</i> This pressure is calculated by subtracting the negative manufacturing range from the specified burst pressure. The minimum marked burst pressure is used to calculate the operating ratio.
50.	<i>Operating Ratio:</i> See 1.2.3.3q for definition. The operating ratio is used to evaluate the proper selection of the rupture disk and is calculated as follows: (a) For marked pressures above 40 psig the operating ratio is equal to the maximum normal operating pressure divided by the minimum marked burst pressure, (b) For marked pressures 40 psig and below, the operating ratio is equal to the maximum normal operating pressure divided by the minimum marked burst pressure, less 2 psig.
51.	<i>Maximum Flow Resistance Factor (k):</i> When using the total flow resistance method to size relief piping components, specify the maximum flow resistance factor required for the rupture disk. The maximum flow resistance factor is expressed as a velocity head loss.
52.	<i>Rupture Disk Materials:</i> The user is responsible for selecting and specifying rupture disk materials that are compatible with system fluids. Verify the selected materials are available for the rupture disk type, pressure, and temperature specified above.
53.	<i>Manufacturer's Data:</i> When available specify the manufacturer's name and lot number. If the rupture disk has been previously ordered, the manufacturer will have lot number traceability to the previous order rupture disk specifications.

RUPTURE DISK DEVICE SPECIFICATION SHEET		Sheet No. _____ Page of _____			
		Requisition No. _____			
		Job No. _____			
		Date _____			
		Revised _____ By _____			
General					
1.	Item Number		3.	Service, Line, or Equip. No.	
2.	Tag Number		4.	Design Code or Standard	
Service Conditions (include applicable units)					
5.	Vessel or Piping MAWP				
6.	Fluid				
7.	Fluid State (initiating rupture)				
8.	Fluid State (relieving conditions)				
9.	Required Relieving Capacity				
10.	Molecular Weight or Specific Gravity				
11.	Viscosity at Relieving Temperature				
12.	Compressibility Factor (Z)				
13.	Specific Heat Ratio				
14.	Normal Maximum Operating Pressure				
15.	Normal Maximum Operating Temperature				
16.	Pressure Fluctuations (static, cyclic, pulsating)				
17.	Superimposed Back Pressure				
18.	Built-up, Back Pressure				
19.	Back Pressure				
20.	Inlet Vacuum Conditions				
21.	Outlet Vacuum Conditions				
22.	Disk Located Upstream of Valve (yes/no)				
23.	Disk Located Downstream of Valve (yes/no)				
24.	Nonfragmenting Design (yes/no)				
Connections					
25.	Nominal Pipe Size		27.	Flange Face (inlet/outlet)	
26.	Flange Standard & Class		28.	Piping Schedule or Bore	
Rupture Disk Holder			Rupture Disk		
29.	Holder Tag No.		41.	Nominal Disk Size	
30.	Nominal Holder Size		42.	Disk Type	
31.	Design Type		43.	Model Designator	
32.	Model Designator		44.	Quantity Required	
33.	Quantity Required		45.	Manufacturing Range	
34.	Holder Material (inlet)		46.	Specified Burst Temperature	
35.	Holder Material (outlet)		47.	Specified Burst Pressure	
36.	Gauge Tap (yes/no) & Size		48.	Max Marked Burst Pressure	
Accessories			49.	Min Marked Burst Pressure	
37.	Studs & Nuts (y/n) & Matl		50.	Operating Ratio	
38.	Jackscrews (yes/no)		51.	Max Flow Resistance K_R	
39.	Telltale Assy (y/n) & Matl		52.	Rupture Disk Materials	
40.	Other				
			53.	Manufacturer's Data	

Note: Indicate items to be filled in by the manufacturer with an asterisk (*).

Figure A-1 —Rupture Disk Device Specification Sheet

APPENDIX B—REVIEW OF FLOW EQUATIONS USED IN SIZING PRESSURE RELIEF VALVES FOR GAS OR VAPOR

B.1 Development of Flow Equations

B.1.1 The development of the vapor flow equation has been outlined in various places including standard thermodynamic texts and papers presented to API. Basically, the equation is determined by a mass and energy balance around the pressure relief valve nozzle. Since the pressure changes as the vapor is accelerated in the nozzle, a relationship between pressure and volume is required to describe the changes in energy that occur. This pressure-volume relationship is described along an isentropic path to permit calculation of the maximum flow that can be obtained in a nozzle and serves as a reference point to determine the efficiency of an actual nozzle. The equation obtained is rearranged algebraically to include only those variables that are readily available at the inlet of the pressure relief valve.

B.1.2 The vapor flow equations of 3.6 used to determine the capacity of a pressure relief valve were developed under the following assumptions:

- a. That the ideal gas laws adequately described the pressure-volume relationship of the expanding vapor.
- b. That no heat was transferred to or from the nozzle of the pressure relief valve (that is, adiabatic flow).
- c. That the vapor expansion followed an isentropic path.

B.1.3 The assumption in Item b is representative of the conditions obtained in the nozzle of a pressure relief valve and does not impact the capacity equation to a significant degree. The assumption in item c that the vapor expands isentropically only provides a convenient means to determine the maximum capacity of a particular nozzle. The actual capacity of the nozzle is determined by a flow test and the coefficient of discharge (the ratio of actual flow to the theoretical flow), K_d , becomes a derating factor applied to the flow equation.

B.1.4 The assumption that the vapor obeys the ideal gas laws refers only to the pressure-volume relationship that is obtained during an isentropic expansion. This relationship can specifically be described by the following equation:

$$PV^k = \text{constant}$$

where

P = pressure.

V = volume.

k = specific heat ratio.

B.1.5 This relationship affects the capacity equation through the coefficient C , which is a function of the specific heat ratio. (See Figure 32.)

B.1.6 Even though many vapors encountered in refinery service do not follow the ideal gas laws, in most cases a pressure relief valve (PRV) is adequately sized based on this assumption. However, there may be unusual situations where deviations from ideal behavior are significant. In those cases, an isentropic expansion coefficient is used to characterize the actual pressure-volume relationship that exists in the PRV nozzle. Since this coefficient is used in the same way as the ideal specific heat ratio, the form of the vapor sizing equation is identical. The coefficient C is calculated for a real gas using the isentropic expansion coefficient n instead of the specific heat ratio k .

B.1.7 Determining the isentropic expansion coefficient for a real gas is somewhat complicated because it is a function of both pressure and temperature and it will vary throughout the expansion process (for an ideal gas the isentropic expansion coefficient will remain constant). The coefficient can generally be obtained from an equation of state that describes the pressure-volume relationship along any thermodynamic path but is restricted to an isentropic expansion path.

B.1.8 Alternatively, an isentropic expansion coefficient can be used based on an average value between the upstream pressure and the pressure in the throat of the nozzle which, in the case of maximum flow, is the critical-flow pressure.

APPENDIX C—PRESSURE RELIEF VALVE SPECIFICATION SHEETS

C.1 Instructions—Spring-Loaded Pressure Relief Valve Specification Sheet

Line No.	Instruction
1.	Fill in item number.
2.	Fill in user's pressure relief valve identification number.
3.	Specify service, line, or equipment to be protected.
4.	Specify number of valves required.
5.	Specify the applicable Code(s) and whether Code Symbol nameplate stamping is required.
6.	Valve should comply with API Standard 526.
7.	Check fire or specify other basis of selection.
8.	Specify whether a rupture disk is being used under the valve inlet.
9.	Specify whether valve is conventional, balanced-bellows, and/or balanced piston.
10.	Give description of valve inlet (full nozzle; semi-nozzle, or other type).
11.	Specify open or closed bonnet.
12.	Specify metal-to-metal or resilient seat.
13.	If other than API 527, specify seat test requirements.
14.	Specify pipe size of inlet, flange rating, and type of facing.
15.	Specify pipe size of outlet, flange rating, and type of facing.
16.	Specify type of connection if other than flanged (e.g., threaded, socket weld, etc.).
17.	Specify material of body.
18.	Specify material of bonnet.
19.	Specify material of seat or nozzle and disk.
20.	If a resilient seal is required, specify material.
21.	Specify material of guide.
22.	Specify material of adjusting ring or rings.
23.	Specify material of spring and spring washer.
24.	Specify material of bellows.
25.	Specify material of balanced piston.
26.	Specify if materials should comply with NACE MR0175.
27.	Specify any other special material requirements.
28.	Specify screwed or bolted cap.
29.	Specify if the valve is to have a plain or packed lifting lever, or none.
30.	Specify whether a test gauge is required.
31.	Specify whether a bug screen in a bonnet vent of a bellows, or balanced piston valve is required.
32.	Specify other accessories that are required (e.g., limit switch).

Line No.	Instruction
33.	Indicate flowing fluid and state (liquid, gas, or vapor).
34.	Specify quantity of fluid that the valve is required to relieve at relieving conditions and unit of measure (such as pounds per hr, gal per min, or cu ft per min).
35.	Specify the molecular weight or specific gravity of the fluid at the flowing temperature.
36.	Specify viscosity and unit of measure at the flowing temperature.
37.	Specify operating pressure and unit of measure.
38.	Specify set pressure and unit of measure.
39.	Specify maximum blowdown as a percent of set pressure if different than manufacturer's standard.
40.	Specify the latent heat of vaporization.
41.	Specify the operating temperature and unit of measure.
42.	Specify the actual temperature at relieving conditions and unit of measure.
43.	Specify the increase in pressure in the discharge header as a result of flow.
44.	Specify the amount of superimposed back pressure that normally exists on the valve outlet and unit of measure. If back pressure is variable; specify the minimum and maximum.
45.	Specify the set pressure at which the valve is adjusted to open on the test stand. The cold differential test pressure includes corrections to the set pressure for the service conditions of back pressure, or temperature, or both.
46.	Specify the overpressure allowed, as a percent of set pressure or as a unit of measure.
47.	Specify the compressibility factor, if used.
48.	Give the specific heat ratio as $k = C_p/C_v$.
49.	Specify the calculated orifice area, in square inches.
50.	Specify the selected effective orifice area in square inches.
51.	Specify the letter designation of the selected orifice.
52.	Fill in the name of the manufacturer, if desired.
53.	Fill in the manufacturer's model or type numbers, if desired.
54.	Confirmation of orifice sizing calculations required from vendor.

SPRING-LOADED PRESSURE RELIEF VALVE SPECIFICATION SHEET			Sheet No. _____ Page _____ of _____
			Requisition No. _____
			Job No. _____
			Date _____
			Revised _____
			By _____
GENERAL			BASIS OF SELECTION
1.	Item Number:		5. Code: ASME VIII <input type="checkbox"/> Stamp Required: Yes <input type="checkbox"/> No <input type="checkbox"/>
2.	Tag Number:		Other <input type="checkbox"/> Specify: _____
3.	Service, Line, or Equipment Number:		6. Comply with API 526: Yes <input type="checkbox"/> No <input type="checkbox"/>
4.	Number Required:		7. Fire <input type="checkbox"/> Other <input type="checkbox"/> Specify: _____
			8. Rupture Disk: Yes <input type="checkbox"/> No <input type="checkbox"/>
VALVE DESIGN			MATERIALS
9.	Design Type:		17. Body:
	Conventional <input type="checkbox"/> Bellows <input type="checkbox"/> Balanced Piston <input type="checkbox"/>		18. Bonnet:
10.	Nozzle Type: Full <input type="checkbox"/> Semi <input type="checkbox"/>		19. Seat (Nozzle): _____ Disk: _____
	Other <input type="checkbox"/> Specify: _____		20. Resilient Seat:
11.	Bonnet Type: Open <input type="checkbox"/> Closed <input type="checkbox"/>		21. Guide:
12.	Seat Type: Metal-to-Metal <input type="checkbox"/> Resilient <input type="checkbox"/>		22. Adjusting Ring(s):
13.	Seat Tightness: API 527 <input type="checkbox"/>		23. Spring: _____ Washer: _____
	Other <input type="checkbox"/> Specify: _____		24. Bellows:
CONNECTIONS			25. Balanced Piston:
14.	Inlet Size: _____ Rating: _____ Facing: _____		26. Comply with NACE MR0175: Yes <input type="checkbox"/> No <input type="checkbox"/>
15.	Outlet Size: _____ Rating: _____ Facing: _____		27. Other <input type="checkbox"/> Specify: _____
16.	Other <input type="checkbox"/> Specify: _____		
SERVICE CONDITIONS			ACCESSORIES
33.	Fluid and State:		28. Cap: Screwed <input type="checkbox"/> Bolted <input type="checkbox"/>
34.	Required Capacity per Valve and Units:		29. Lifting Lever: Plain <input type="checkbox"/> Packed <input type="checkbox"/> None <input type="checkbox"/>
35.	Molecular Weight or Specific Gravity:		30. Test Gag: Yes <input type="checkbox"/> No <input type="checkbox"/>
36.	Viscosity at Flowing Temperature and Units:		31. Bug Screen: Yes <input type="checkbox"/> No <input type="checkbox"/>
37.	Operating Pressure and Units:		32. Other <input type="checkbox"/> Specify: _____
38.	Set Pressure and Units:		
39.	Blowdown: Standard <input type="checkbox"/> Other <input type="checkbox"/>		
40.	Latent Heat of Vaporization and Units:		
41.	Operating Temperature and Units:		SIZING AND SELECTION
42.	Relieving Temperature and Units:		49. Calculated Orifice Area (in square inches):
43.	Built-up Back Pressure and Units:		50. Selected Effective Orifice Area (in square inches):
44.	Superimposed Back Pressure and Units:		51. Orifice Designation (letter):
45.	Cold Differential Test Pressure and Units:		52. Manufacturer:
46.	Allowable Overpressure in Percent or Units:		53. Model Number:
47.	Compressibility Factor, Z :		54. Vendor Calculations Required: Yes <input type="checkbox"/> No <input type="checkbox"/>
48.	Ratio of Specific Heats:		

Note: Indicate items to be filled in by the manufacturer with an asterisk (*).

Figure C-1—Spring-Loaded Pressure Relief Valve Specification Sheet

C.2 Instructions—Pilot-Operated Pressure Relief Valve Specification Sheet

Line No.	Instruction
1.	Fill in item number.
2.	Fill in user's pressure relief valve identification number.
3.	Specify service, line, or equipment to be protected.
4.	Specify number of valves required.
5.	Specify the applicable Code(s) and whether Code Symbol nameplate stamping is required.
6.	Valve should comply with API Standard 526.
7.	Check fire or specify other basis of selection.
8.	Specify whether a rupture disk is being used under the valve inlet.
9.	Specify type of main valve operation.
10.	Specify number of pilots per main valve.
11.	Specify if pilot is flow or nonflowing type.
12.	Specify type of action, pop or modulating.
13.	Specify sensing point as integral at main valve inlet or at a remote location.
14.	Specify metal-to-metal or resilient seat.
15.	If other than API 527, specify seat tightness test requirements.
16.	Specify if pilot venting is to atmosphere, valve outlet, or other closed system.
17.	Specify pipe size of inlet, flange rating, and type of facing.
18.	Specify pipe size of outlet, flange rating, and type of facing.
19.	Specify type of connection if other than flanges (e.g., threaded, socket weld, etc.).
20.	Specify material of body.
21.	Specify material of seat or nozzle and piston.
22.	Specify material of resilient seat (if required) and seals.
23.	Specify material of piston seal.
24.	Specify material of piston liner or guide.
25.	Specify material of diaphragm or bellows.
26.	Specify material of pilot body and bonnet.
27.	Specify material of pilot internals.
28.	Specify material of seat and seals of the pilot.
29.	Specify material of diaphragm.
30.	Specify material of tubing and fittings.
31.	Specify material of filter body and cartridge.
32.	Specify material of spring.
33.	Specify if materials should comply with NACE MR0175.
34.	Specify any other special material requirements.

Line No.	Instruction
35.	Specify if external filter is required.
36.	Specify if valve is to have a plain or packed lifting level; or none.
37.	Specify if field test connection is required.
38.	Specify if field test indicator is required.
39.	Specify if backflow preventer is required.
40.	Specify if manual blowdown valve is required.
41.	Specify if test gauge is required.
42.	Specify other accessories that are required.
43.	Indicate flowing fluid and state (liquid, gas, or vapor).
44.	Specify quantity of fluid that the valve is required to relieve at relieving conditions and unit of measure (such as pounds per hr, gal per min, or cu ft per min).
45.	Specify the molecular weight or specific gravity of the fluid at the flowing temperature.
46.	Specify viscosity and unit of measure at the flowing temperature.
47.	Specify operating pressure and unit of measure.
48.	Specify set pressure and unit of measure.
49.	Specify the maximum blowdown as a percent of set pressure if different than manufacturer's standard.
50.	Specify the latent heat of vaporization and unit of measure.
51.	Specify the operating temperature and unit of measure.
52.	Specify the actual temperature at relieving conditions and unit of measure.
53.	Specify the increase in pressure in the discharge header as a result of flow.
54.	Specify the amount of superimposed back pressure that normally exists on the valve outlet and unit of measure. If back pressure is variable; specify the minimum and maximum.
55.	Specify the set pressure at which the valve is adjusted to open on the test stand. The cold differential test pressure includes corrections to the set pressure for the service conditions of back pressure or temperature or both.
56.	Specify the overpressure allowed, as a percent of set pressure or as a unit of measure.
57.	Specify the compressibility factor, if used.
58.	Give the specific heat ratio as $k = C_p / C_v$
59.	Specify the compressibility factor, if used.
60.	Specify the selected effective orifice area in square inches.
61.	Specify the letter designation of the selected orifice.
62.	Fill in the name of the manufacturer, if desired.
63.	Fill in the manufacturer's model or type numbers, if desired.
64.	Confirmation of orifice sizing calculations required from vendor.

PILOT-OPERATED PRESSURE RELIEF VALVE SPECIFICATION SHEET			Sheet No. _____ Page _____ of _____	
			Requisition No. _____	
			Job No. _____	
			Date _____	
			Revised _____	
			By _____	
GENERAL			BASIS OF SELECTION	
1.	Item Number:		5.	Code: ASME VIII <input type="checkbox"/> Stamp Required: Yes <input type="checkbox"/> No <input type="checkbox"/>
2.	Tag Number:			Other <input type="checkbox"/> Specify: _____
3.	Service, Line, or Equipment Number:		6.	Comply with API 526: Yes <input type="checkbox"/> No <input type="checkbox"/>
4.	Number Required:		7.	Fire <input type="checkbox"/> Other <input type="checkbox"/> Specify: _____
			8.	Rupture Disk: Yes <input type="checkbox"/> No <input type="checkbox"/>
VALVE DESIGN			MATERIALS, MAIN VALVE	
9.	Design Type: Piston <input type="checkbox"/> Diaphragm <input type="checkbox"/> Bellows <input type="checkbox"/>		20.	Body:
10.	Number of Pilots:		21.	Seat (Nozzle): Piston:
11.	Pilot Type: Flowing <input type="checkbox"/> Nonflowing <input type="checkbox"/>		22.	Resilient Seat: Seals:
12.	Pilot Action: Pop <input type="checkbox"/> Modulating <input type="checkbox"/>		23.	Piston Seal:
13.	Pilot Sense: Internal <input type="checkbox"/> Remote <input type="checkbox"/>		24.	Piston Liner/Guide:
14.	Seat Type: Metal-to-Metal <input type="checkbox"/> Resilient <input type="checkbox"/>		25.	Diaphragm/Bellows:
15.	Seat Tightness: API 527 <input type="checkbox"/>			
	Other <input type="checkbox"/> Specify: _____		MATERIALS, PILOT	
16.	Pilot Vent: Atmosphere <input type="checkbox"/> Outlet <input type="checkbox"/>		26.	Body/Bonnet:
	Other <input type="checkbox"/> Specify: _____		27.	Internals:
			28.	Seat: Seals:
CONNECTIONS			29.	Diaphragm:
			30.	Tubing/Fittings:
14.	Inlet Size: Rating: Facing:		31.	Filter Body: Cartridge:
15.	Outlet Size: Rating: Facing:		32.	Spring:
16.	Other <input type="checkbox"/> Specify: _____		33.	Comply with NACE MR0175: Yes <input type="checkbox"/> No <input type="checkbox"/>
			34.	Other <input type="checkbox"/> Specify: _____
SERVICE CONDITIONS			ACCESSORIES	
43.	Fluid and State:		35.	External Filter: Yes <input type="checkbox"/> No <input type="checkbox"/>
44.	Required Capacity per Valve and Units:		36.	Lifting Lever: Plain <input type="checkbox"/> Packed <input type="checkbox"/> None <input type="checkbox"/>
45.	Molecular Weight or Specific Gravity:		37.	Field Test Connection: Yes <input type="checkbox"/> No <input type="checkbox"/>
46.	Viscosity at Flowing Temperature and Units:		38.	Field Test Indicator: Yes <input type="checkbox"/> No <input type="checkbox"/>
47.	Operating Pressure and Units:		39.	Backflow Preventer: Yes <input type="checkbox"/> No <input type="checkbox"/>
48.	Set Pressure and Units:		40.	Manual Blowdown Valve: Yes <input type="checkbox"/> No <input type="checkbox"/>
49.	Blowdown: Standard <input type="checkbox"/> Other <input type="checkbox"/>		41.	Test Gauge: Yes <input type="checkbox"/> No <input type="checkbox"/>
50.	Latent Heat of Vaporization and Units:		42.	Other <input type="checkbox"/> Specify: _____
51.	Operating Temperature and Units:		SIZING AND SELECTION	
52.	Relieving Temperature and Units:		59.	Calculated Orifice Area (in square inches):
53.	Built-up Back Pressure and Units:		60.	Selected Effective Orifice Area (in square inches):
54.	Superimposed Back Pressure and Units:		61.	Orifice Designation (letter):
55.	Cold Differential Test Pressure and Units:		62.	Manufacturer:
56.	Allowable Overpressure in Percent or Units:		63.	Model Number:
57.	Compressibility Factor, Z:		64.	Vendor Calculations Required: Yes <input type="checkbox"/> No <input type="checkbox"/>
58.	Ratio of Specific Heats:			

Note: Indicate items to be filled in by the manufacturer with an asterisk (*).

Figure C-2—Pilot-Operated Pressure Relief Valve Specification Sheet

APPENDIX D—SIZING FOR TWO-PHASE LIQUID/VAPOR RELIEF

D.1 Sizing for Two-Phase Liquid/Vapor Relief

D.1.1 The method for two-phase sizing, presented in this Appendix, is one of several techniques currently in use and newer methods are continuing to evolve as time goes on. It is recommended that the particular method to be used for a two-phase application be fully understood. It should be noted that the methods presented in this Appendix have not been validated by test, nor is there any recognized procedure for certifying the capacity of pressure relief valves in two-phase flow service.

D.1.2 Many different scenarios are possible under the general category of two-phase liquid/vapor relief. In all of these scenarios either a two-phase mixture enters the pressure relief valve (PRV) or a two-phase mixture is produced as the fluid moves through the valve. Vapor generation as a result of flashing must be taken into account, since it may reduce the effective mass flow capacity of the valve. The methods presented in D.2.1 through D.2.3 can be used for sizing pressure relief valves in two-phase liquid/vapor scenarios. In addition, D.2.1 can be used for supercritical fluids in condensing two-phase flow. Use Table D.1 to determine which section to consult for a particular two-phase relief scenario.

D.1.3 The equations presented in sections D.2.1 through D.2.3 are based on the Leung omega method [12]. This method is based on the following assumption (Other specific assumptions or limitations are presented in the appropriate section).

Note: For high momentum discharges of two-phase systems, both thermal and mechanical equilibrium can be assumed. These assumptions correspond to the homogeneous equilibrium flow model (HEM).

D.1.4 A more rigorous approach using vapor/liquid equilibrium (VLE) models incorporated into computerized analytical methods based on HEM can be considered.

D.1.5 For information about saturated water, see specifically Section VIII, Appendix 11, of the ASME Code.

D.2 Sizing Methods

D.2.1 SIZING FOR TWO-PHASE FLASHING OR NONFLASHING FLOW THROUGH A PRESSURE RELIEF VALVE

D.2.1.1 GENERAL

The method presented in this section can be used for sizing pressure relief valves handling either flashing or nonflashing flow. For flashing flow, the two-phase system must consist of a saturated liquid and saturated vapor and contain no noncondensable gas. For nonflashing flow, the two-phase system must consist of a highly subcooled liquid and either a noncondensable gas, condensable vapor or both. Fluids both above and below the thermodynamic critical point in condensing two-phase flow can be handled as well. The following procedure can be used.

Table D-1 — Two-Phase Liquid/Vapor Relief Scenarios for Pressure Relief Valves

Two-Phase Liquid/Vapor Relief Scenario	Example	Section
Two-phase system (saturated liquid and saturated vapor) enters PRV and flashes. No noncondensable ^a gas present. Also includes fluids both above and below the thermodynamic equilibrium point in condensing two-phase flow.	Saturated liquid/vapor propane system enters PRV and the liquid propane flashes.	Section D.2.1
Two-phase system (highly subcooled ^b liquid and either non-condensable gas, condensable vapor or both) enters PRV and does not flash.	Highly subcooled propane and nitrogen enters PRV and the propane does not flash.	Section D.2.1
Subcooled (including saturated) liquid enters PRV and flashes. No condensable vapor or noncondensable gas present.	Subcooled propane enters PRV and flashes.	Section D.2.2
Two-phase system (noncondensable gas or both condensable vapor and non-condensable gas and either subcooled or saturated liquid) enters PRV and flashes. Noncondensable gas present.	Saturated liquid/vapor propane system and nitrogen enters PRV and the liquid propane flashes.	Section D.2.3

^aA noncondensable gas is a gas that is not easily condensed under normal process conditions. Common noncondensable gases include air, oxygen, nitrogen, hydrogen, carbon dioxide, carbon monoxide, and hydrogen sulfide.

^bThe term highly *subcooled* is used to reinforce that the liquid does not flash passing through the PRV.

Step 1—Calculate the Omega Parameter, ω

For flashing multi-component systems with nominal boiling range² less than 150°F or flashing single-component systems, use either Equation D.1, D.2, or D.3. If Equation D.1 or D.2 is used, the single-component system must be far from its thermodynamic critical point³ ($T_r \leq 0.9$ or $P_r \leq 0.5$).

$$\omega = \frac{x_o v_{vo}}{v_o} \left(1 - \frac{0.37 P_o v_{vlo}}{h_{vlo}} \right) + \frac{0.185 C_p T_o P_o}{v_o} \left(\frac{v_{vlo}}{h_{vlo}} \right)^2 \quad (\text{D.1})$$

$$\omega = \frac{x_o v_{vo}}{v_o k} + \frac{0.185 C_p T_o P_o}{v_o} \left(\frac{v_{vlo}}{h_{vlo}} \right)^2 \quad (\text{D.2})$$

where

x_o = vapor mass fraction (quality) at the **PRV** inlet.

v_{vo} = specific volume of the vapor at the **PRV** inlet (ft³/lb).

v_o = specific volume of the two-phase system at the **PRV** inlet (ft³/lb).

P_o = pressure at the **PRV** inlet (psia). This is the **PRV** set pressure (psig) plus the allowable overpressure (psi) plus atmospheric pressure.

v_{vlo} = difference between the vapor and liquid specific volumes at the **PRV** inlet (ft³/lb).

h_{vlo} = latent heat of vaporization at the **PRV** inlet (Btu/lb). For multi-component systems, h_{vlo} is the difference between the vapor and liquid specific enthalpies.

C_p = liquid specific heat at constant pressure at the **PRV** inlet (Btu/lb • °R).

T_o = temperature at the **PRV** inlet (OR).

k = ratio of specific heats of the vapor. If the specific heat ratio is unknown, a value of 1.0 can be used.

For flashing multi-component systems with nominal boiling range greater than 150°F, single-component systems near the thermodynamic critical point, or supercritical fluids in condensing two-phase flow, use Equation D.3.

$$\omega = 9 \left(\frac{v_g}{v_o} - 1 \right) \quad (\text{D.3})$$

²The nominal boiling range is the difference in the atmospheric boiling points of the lightest and heaviest components in the system.

³Other assumptions that apply include: ideal gas behavior, heat of vaporization and the heat capacity of the fluid are constant throughout the nozzle, behavior of the fluid vapor pressure with temperature follows the Clapeyron equation; and isenthalpic (constant enthalpy) flow process.

where

v_g = specific volume evaluated at 90% of the **PRV** inlet pressure P_o (ft³/lb). When determining v_g , the flash calculation should be carried out isentropically, but an isenthalpic (adiabatic) flash is sufficient.

v_o = specific volume of the two-phase system at the **PRV** inlet (ft³/lb).

For nonflashing systems, use Equation D.4.

$$\omega = \frac{x_o v_{vgo}}{v_o k} \quad (\text{D.4})$$

where

x_o = vapor, gas, or combined vapor and gas mass fraction (quality) at the **PRV** inlet.

v_{vgo} = specific volume of the vapor, gas or combined vapor and gas at the **PRV** inlet (ft³/lb).

v_o = specific volume of the two-phase system at the **PRV** inlet (ft³/lb).

k = ratio of specific heats of the vapor, gas or combined vapor and gas. If the specific heat ratio is unknown, a value of 1.0 can be used.

Step 2—Determine if the Flow is Critical or Subcritical

$$P_c > P_a \Rightarrow \text{critical flow}$$

$$P_c < P_a \Rightarrow \text{subcritical flow}$$

where

P_c = critical pressure (psia).

$$P_c = \eta_c P_o$$

η_c = critical pressure ratio from Figure D.1. This ratio can also be obtained from the following expression:

$$= \eta_c^2 + (\omega^2 - 2\omega)(1 - \eta_c)^2 + 2\omega^2 \ln \eta_c + 2\omega^2(1 - \eta_c) = 0$$

P_o = pressure at the **PRV** inlet (psia). This is the **PRV** set pressure (psig) plus the allowable overpressure (psi) plus atmospheric pressure.

P_a = downstream back pressure (psia).

Step 3—Calculate the Mass Flux

For critical flow, use Equation D.5. For subcritical flow, use Equation D.6.

$$G = 68.09 \eta_c \sqrt{\frac{P_o}{v_o \omega}} \quad (\text{D.5})$$

$$G = \frac{68.09 \{ -2 [\omega \ln \eta_a + (o-1)(1-\eta_a)] \}^{1/2} \sqrt{P_o/v_o}}{\omega \left(\frac{1}{\eta_a} - 1 \right) + 1} \quad (\text{D.6})$$

where

G = mass flux (lb/s·ft²).

η_a = back pressure ratio.

$$\eta_a = \frac{P_a}{P_o}$$

Step 4—Calculate the Required Area of the PRV

$$A = \frac{0.04 W}{K_d K_b K_c G} \quad (\text{D.7})$$

where

A = required effective discharge area (in.²).

W = mass flow rate (lb/hr).

K_d = discharge coefficient that should be obtained from the valve manufacturer. For a preliminary sizing estimation, a discharge coefficient of 0.85 can be used.

K_b = back pressure correction factor for vapor that should be obtained from the valve manufacturer. For a preliminary sizing estimation, use Figure D.2. The back pressure correction factor applies to balanced-bellows valves only.

K_c = combination correction factor for installations with a rupture disk upstream of the pressure relief valve (See 3.11.2).

= 1.0 when a rupture disk is not installed,

= 0.9 when a rupture disk is installed in combination with a pressure relief valve and the combination does not have a published value.

D.2.1.2 Example

In this example, the following relief requirements are given:

- Required crude column overhead two-phase flow rate caused by an operational upset of 477,430 lb/hr. This flow is downstream of the condenser.
- Temperature at the PRV inlet of 200°F (659.7 R).

c. Relief valve set at 60 psig, the design pressure of the equipment.

d. Downstream back pressure of 15 psig (29.7 psia) (superimposed back pressure = 0 psig, built-up back pressure = 15 psig).

e. Two-phase specific volume at the PRV inlet of 0.3116 ft³/lb.

In this example, the following data are derived:

- Permitted accumulation of 10%.
- Relieving pressure of 1.10 × 60 = 66 psig (80.7 psia).
- Percent of gauge back pressure = (15/60) × 100 = 25%. Thus, the back pressure correction factor K_b = 1.0 (from Figure D-2). Since the downstream built-up back pressure is greater than 10% of the set pressure, a balanced pressure relief valve should be used.

Step 1—Calculate the Omega Parameter, ω

Since the crude column overhead system is a flashing multi-component system with nominal boiling range greater than 150°F, Equation D.3 is chosen to calculate the omega parameter, ω . The specific volume evaluated at 0.9 × 80.7 = 72.63 psia using the results of an isenthalpic (adiabatic) flash calculation from a process simulator is 0.3629 ft³/lb. The omega parameter is calculated from Equation D.3 as follows:

$$\omega = 9 \left(\frac{0.3629}{0.3116} - 1 \right)$$

$$= 1.482$$

Step 2—Determine if the Flow is Critical or Subcritical

The critical pressure ratio, η_c , is 0.66 (from Figure D-1). The critical pressure P_c is calculated as follows:

$$P_c = 0.66 \times 80.7$$

$$= 53.26 \text{ psia}$$

The flow is determined to be critical since $P_c > P_a$.

$$53.26 > 29.7$$

Step 3—Calculate the Mass Flux

The mass flux G is calculated from Equation D.5 as follows:

$$G = 68.09 \times 0.66 \times \sqrt{\frac{80.7}{0.3116 \times 1.482}}$$

$$= 594.1 \text{ lb/s} \cdot \text{ft}^2$$

Step 4—Calculate the Required Area of the PRV

The required area of the pressure relief valve **A** is calculated from Equation D.7 as follows:

$$A = \frac{0.04 \times 477,430}{0.85 \times 1 \times 1 \times 594.1}$$

$$= 37.8 \text{ in.}^2$$

Select two (2) "Q" orifice and (1) "R" orifice pressure relief valves ($2 \times 11.05 + 1 \times 16.00 = 38.1 \text{ in.}^2$).

Since this example resulted in multiple valves, the required area could be re-calculated at 16% overpressure.

D.2.2 SIZING FOR SUBCOOLED LIQUID AT THE PRESSURE RELIEF VALVE INLET

D.2.2.1 General

The method presented in this section can be used for sizing pressure relief valves handling a subcooled (including saturated) liquid at the inlet. No condensable vapor or non-condensable gas should be present at the inlet. The subcooled liquid either flashes upstream or downstream of the pressure relief valve throat depending on which subcooling region the flow falls into. The equations in this section also apply to all-liquid scenarios. The following procedure can be used.

Step 1—Calculate the Saturated Omega Parameter, ω_s

For multi-component systems with nominal boiling range⁴ less than 150°F or single-component systems, use either Equation D.8 or D.9. If Equation D.8 is used, the fluid must be far from its thermodynamic critical point ($T_c \leq 0.9$ or $P_c \leq 0.5$).⁵

$$\omega_s = 0.185 \rho_{lo} C_p T_o P_s \left(\frac{v_{vls}}{h_{vls}} \right)^2 \quad (\text{D.8})$$

where

ρ_{lo} = liquid density at the PRV inlet (lb/ft³).

C_p = liquid specific heat at constant pressure at the PRV inlet (Btu/lb • R).

⁴The nominal boiling range is the difference in the atmospheric boiling points of the lightest and heaviest components in the system.

⁵Other assumptions that apply include: heat of vaporization and the heat capacity of the fluid are constant throughout the nozzle, behavior of the fluid vapor pressure with temperature follows the Clapeyron equation, and isenthalpic (constant enthalpy) flow process.

T_o = temperature at the PRV inlet (R).

P_s = saturation (vapor) pressure corresponding to T_o (psia). For a multi-component system, use the bubble point pressure corresponding to T_o .

v_{vls} = difference between the vapor and liquid specific volumes at P_s (ft³/lb).

h_{vls} = latent heat of vaporization at P_s (Btu/lb). For multi-component systems, h_{vls} is the difference between the vapor and liquid specific enthalpies at P_s .

For multi-component systems with nominal boiling range greater than 150°F or single-component systems near the thermodynamic critical point, use Equation D.9.

$$\omega_s = 9 \left(\frac{\rho_{lo}}{\rho_9} - 1 \right) \quad (\text{D.9})$$

where

ρ_{lo} = liquid density at the PRV inlet (lb/ft³).

ρ_9 = density evaluated at 90% of the saturation (vapor) pressure P_s corresponding to the PRV inlet temperature T_o (lb/ft³). For a multi-component system, use the bubble point pressure corresponding to T_o for P_s . When determining ρ_9 , the flash calculation should be carried out isentropically, but an isenthalpic (adiabatic) flash is sufficient.

Step 2—Determine the Subcooling Region

$P_s > \eta_{st} P_o \Rightarrow$ low subcooling region (flashing occurs upstream of throat)

$P_s < \eta_{st} P_o \Rightarrow$ high subcooling region (flashing occurs at the throat)

where

η_{st} = transition saturation pressure ratio

$$= \frac{2\omega_s}{1 + 2\omega_s}$$

P_o = pressure at the PRV inlet (psia). This is the PRV set pressure (psig) plus the allowable overpressure (psi) plus atmospheric pressure.

Step 3—Determine if the Flow is Critical or Subcritical

For the low subcooling region, use the following comparisons.

$$P_c > P_a \Rightarrow \text{critical flow}$$

$$P_c < P_a \Rightarrow \text{subcritical flow}$$

For the high subcooling region, use the following comparisons.

$$P_s > P_a \Rightarrow \text{critical flow}$$

$$P_s < P_a \Rightarrow \text{subcritical flow (all-liquid flow)}$$

where

$$P_c = \text{critical pressure (psia).}$$

$$= \eta_c P_o$$

$$\eta_c = \text{critical pressure ratio from Figure D.3 using the value of } \eta_s.$$

$$\eta_s = \text{saturation pressure ratio.}$$

$$= \frac{P_s}{P_o}$$

$$P_a = \text{downstream back pressure (psia).}$$

Step 4—Calculate the Mass Flux

In the low subcooling region, use Equation D.10. If the flow is critical, use η_c for η and if the flow is subcritical, use η_a for η . In the high subcooling region, use Equation D.11. If the flow is critical, use P_s for P and if the flow is subcritical (all-liquid flow), use P_a for P .

$$G = \frac{68.09 \left\{ 2(1 - \eta_s) + 2 \left[\omega_s \eta_s \ln \left(\frac{\eta_s}{\eta} \right) - (\omega_s - 1)(\eta_s - \eta) \right] \right\}^{1/2}}{\omega_s \left(\frac{\eta_s}{\eta} - 1 \right) + 1} \sqrt{P_o \rho_{l_o}} \quad (\text{D.10})$$

$$G = 96.3 [\rho_{l_o} (P_o - P)]^{1/2} \quad (\text{D.11})$$

where

$$G = \text{mass flux (lb/s} \cdot \text{ft}^2\text{).}$$

$$\eta_a = \text{back pressure ratio}$$

$$= \frac{P_a}{P_o}$$

Step 5—Calculate the Required Area of the PRV

The following equation is only applicable to turbulent flow systems. Most two-phase relief scenarios will be within the turbulent flow regime.

$$A = 0.3208 \frac{Q \rho_{l_o}}{K_d K_b K_c G} \quad (\text{D.12})$$

where

$$A = \text{required effective discharge area (in.}^2\text{).}$$

$$Q = \text{volumetric flow rate (gal/min).}$$

$$K_d = \text{discharge coefficient that should be obtained from the valve manufacturer. For a preliminary sizing estimation, a discharge coefficient 0.65 for subcooled liquids and 0.85 for saturated liquids can be used.}$$

$$K_b = \text{back pressure correction factor for liquid that should be obtained from the valve manufacturer. For a preliminary sizing estimation, use Figure D.4. The back pressure correction factor applies to balanced-bellows valves only.}$$

$$K_c = \text{combination correction factor for installations with a rupture disk upstream of the pressure relief valve (see 3.11.2).}$$

$$= 1.0 \text{ when a rupture disk is not installed,}$$

$$= 0.9 \text{ when a rupture disk is installed in combination with a pressure relief valve and the combination does not have a published value.}$$

D.2.2.2 Example

In this example, the following relief requirements are given:

- Required propane volumetric flow rate caused by blocked in pump of 100 gal/min.
- Relief valve set at 260 psig, the design pressure of the equipment.
- Downstream total back pressure of 10 psig (24.7 psia) (superimposed back pressure = 0 psig, built-up back pressure = 10 psig).
- Temperature at the PRV inlet of 60°F (519.67 R).
- Liquid propane density at the PRV inlet of 31.92 lb/ft³.
- Liquid propane specific heat at constant pressure at the PRV inlet of 0.6365 Btu/lb·R.
- Saturation pressure of propane corresponding to 60°F of 107.6 psia.
- Specific volume of propane liquid at the saturation pressure of 0.03160 ft³/lb.

- i. Specific volume of propane vapor at the saturation pressure of 1001 ft³/lb.
- j. Latent heat of vaporization for propane at the saturation pressure of 152.3 Btu/lb.

In this example, the following data are derived:

- a. Permitted accumulation of 10%.
- b. Relieving pressure of $1.10 \times 260 = 286$ psig (300.7 psia).
- c. Percent of gauge back pressure = $(101260) \times 100 = 3.8\%$. Since the downstream built-up back pressure is less than 10% of the set pressure, a conventional pressure relief valve may be used. Thus, the back pressure correction factor $K_b = 1.0$.
- d. Since the propane is subcooled, a discharge coefficient K_d of 0.65 can be used.

Step 1—Calculate the Saturated Omega Parameter ω_s

Since the propane system is a single-component system far from its thermodynamic critical point, the saturated omega parameter ω_s is calculated from Equation D.8 as follows:

$$\omega_s = 0.185 \times 31.92 \times 0.6365 \times 519.67 \times 107.6 \times \left(\frac{1.001 - 0.03160}{152.3} \right)^2$$

$$= 8.515$$

Step 2—Determine the Subcooling Region

The transition saturation pressure ratio η_{st} is calculated as follows:

$$\eta_{st} = \frac{2 \times 8.515}{1 + 2 \times 8.515}$$

$$= 0.9445$$

The liquid is determined to fall into the high subcooling region since $P_s < \eta_{st} P_o$.

$$107.6 < 0.9445 \times 300.7 = 284.0$$

Step 3—Determine if the Flow is Critical or Subcritical

The flow is determined to be critical since $P_s > P_a$.

$$107.6 > 24.7$$

Step 4—Calculate the Mass Flux

The mass flux G is calculated from Equation D.11 as follows:

$$G = 96.3 \times [31.92 \times (300.7 - 107.6)]^{1/2}$$

$$= 7560 \text{ lb/s} \cdot \text{ft}^2$$

Step 5—Calculate the Required Area of the PRV

The required area A of the pressure relief valve is calculated from Equation D.12 as follows:

$$A = 0.3208 \times \frac{100 \times 31.92}{0.65 \times 1 \times 1 \times 7560}$$

$$= 0.208 \text{ in.}^2$$

Select an "F" orifice pressure relief valve (0.307 in.²).

D.2.3 SIZING FOR TWO-PHASE FLASHING FLOW WITH A NONCONDENSABLE GAS THROUGH A PRESSURE RELIEF VALVE

D.2.3.1 General

The method presented in this section can be used for sizing pressure relief valves handling two-phase flashing flow with a noncondensable gas or both a condensable vapor and noncondensable gas. This approach is not valid when the solubility of the noncondensable gas in the liquid is appreciable. For these situations, the method presented in D.2.1 should be used.

In this method, the term vapor (subscript v) will be used to refer to the condensable vapor present in the two-phase flow and the term gas (subscript g) will be used to refer to the noncondensable gas. The following procedure can be used.

Step 1—Calculate the Inlet Void Fraction α

$$\alpha_o = \frac{x_o v_{vgo}}{v_o} \quad (\text{D.13})$$

where

x_o = gas or combined vapor and gas mass fraction (quality) at the PRV inlet.

v_{vgo} = specific volume of the gas or combined vapor and gas at the PRV inlet (ft³/lb).

v_o = specific volume of the two-phase system at the PRV inlet (ft³/lb).

Step 2—Calculate the Omega Parameter, ω

For systems that satisfy all of the following conditions, use Equation D.14.

- a. Contains less than 0.1 weight % hydrogen.
- b. Nominal boiling range⁶ less than 150°F.

⁶The nominal boiling range is the difference in the atmospheric boiling points of the lightest and heaviest components in the system.

- c. Either P_{vo}/P_o less than 0.9 or P_{go}/P_o greater than 0.1.
 d. Far from its thermodynamic critical point ($T_r \geq 0.9$ or $P_r \geq 0.5$).⁷

$$\omega = \frac{\alpha_o}{k} + 0.185(1 - \alpha_o)\rho_{lo}C_pT_oP_{vo}\left(\frac{v_{vlo}}{h_{vlo}}\right)^2 \quad (\text{D.14})$$

where

P_{vo} = saturation (vapor) pressure corresponding to the inlet temperature T_o (psia). For a multi-component system, use the bubble point pressure corresponding to T_o .

P_o = pressure at the PRV inlet (psia). This is the PRV set pressure (psig) plus the allowable overpressure (psi) plus atmospheric pressure.

P_{go} = noncondensable gas partial pressure at the PRV inlet (psia).

k = ratio of specific heats of the gas or combined vapor and gas. If the specific heat ratio is unknown, a value of 1 can be used.

ρ_{lo} = liquid density at the PRV inlet (lb/ft³).

C_p = liquid specific heat at constant pressure at the PRV inlet (Btu/lb·R).

T_o = temperature at the PRV inlet (R).

v_{vlo} = difference between the vapor⁸ (not including any noncondensable gas present) and liquid specific volumes at the PRV inlet (ft³/lb).

h_{vlo} = latent heat of vaporization at the PRV inlet (Btu/lb). For multi-component systems, h_{vlo} is the difference between the vapor and liquid specific enthalpies.

Go to Step 3 to determine if the flow is critical or subcritical.

For systems that satisfy one of the following conditions, use Equation D.15.

- a. Contains more than 0.1 weight % hydrogen.
 b. Nominal boiling range greater than 150°F.

⁷Other assumptions that apply include: ideal gas behavior, heat of vaporization and the heat capacity of the fluid are constant throughout the nozzle, behavior of the fluid vapor pressure with temperature follows the Clapeyron equation, and isenthalpic (constant enthalpy) flow process.

⁸To obtain the vapor specific volume when a noncondensable gas is present at the PRV inlet, use the vapor partial pressure (from the mole composition) and the ideal gas law to calculate the volume.

- c. Either P_{vo}/P_o greater than 0.9 or P_{go}/P_o less than 0.1.
 d. Near its thermodynamic critical point ($T_r \geq 0.9$ or $P_r \geq 0.5$).

$$\omega = 9\left(\frac{v_g}{v_o} - 1\right) \quad (\text{D.15})$$

where

v_g = specific volume evaluated at 90% of the PRV inlet pressure P_o (ft³/lb). When determining v_g , the flash calculation should be carried out isentropically, but an isenthalpic (adiabatic) flash is sufficient.

Go to Step 4 to determine if the flow is critical or subcritical.

Step 3—Determine if the Flow is Critical or Subcritical (ω calculated from Equation D.14)

$P_c > P_a \Rightarrow$ critical flow

$P_c < P_a \Rightarrow$ subcritical flow

where

P_c = critical pressure (psia).

$$= [y_{go}\eta_{gc} + (1 - y_{go})\eta_{vc}]P_o$$

y_{go} = inlet gas mole fraction in the vapor phase. Can be determined using given mole composition information or the following equation.

$$= \frac{P_{go}}{P_o}$$

η_{gc} = nonflashing critical pressure ratio from Figure D.1 using the value of $\omega = \alpha_o/k$.

η_{vc} = flashing critical pressure ratio from Figure D.1 using the value of ω .

P_a = downstream back pressure (psia).

Go to Step 5.

Step 4—Determine if the Flow is Critical or Subcritical (ω calculated from Equation D.15)

$P_c > P_a \Rightarrow$ critical flow

$P_c < P_a \Rightarrow$ subcritical flow

whme

P_c = critical pressure (psia).

$$= \eta_c P_o$$

η_c = critical pressure ratio from Figure D.1. This ratio can also be obtained from the following expression:

$$= qf + (w^2 - 2\omega)(1 - \eta_c)^2 + 2\omega^2 \ln \eta_c + 2\omega^2(1 - \eta_c) = 0$$

P_a = downstream back pressure (psia).

Go to Step 6.

Step 5—Calculate the Mass Flux (ω calculated from Equation D.14)

For critical flow, use Equation D.16.

$$G = 68.09 \left[\frac{P_o}{v_o} \left(\frac{y_{go} \eta_{gc}^2 k}{\alpha_o} + \frac{(1 - y_{go}) \eta_{vc}^2}{\omega} \right) \right]^{1/2} \quad (D.16)$$

where

$$G = \text{mass flux (lb/s} \cdot \text{ft}^2\text{)}.$$

For subcritical flow, an iterative solution is required. Solve Equations D.17 and D.18 simultaneously for η_g and η_v .

$$\eta_a = y_{go} \eta_g + (1 - y_{go}) \eta_v \quad (D.17)$$

$$\frac{\alpha_o}{k} \left(\frac{1}{\eta_g} - 1 \right) = \omega \left(\frac{1}{\eta_v} - 1 \right) \quad (D.18)$$

wherc

η_g = nonflashing partial pressure ratio.

η_v = flashing partial pressure ratio.

Use Equation D.19 to calculate the mass flux.

$$G = [y_{go} G_g^2 + (1 - y_{go}) G_v^2]^{1/2} \quad (D.19)$$

where

G_g = nonflashing mass flux (lb/s \cdot ft²).

$$G_g = \frac{68.09 \left\{ -2 \left[\frac{\alpha_o}{k} \ln \eta_g + \left(\frac{\alpha_o}{k} - 1 \right) (1 - \eta_g) \right] \right\}^{1/2}}{\frac{\alpha_o}{k} \left(\frac{1}{\eta_g} - 1 \right) + 1} \sqrt{P_o / v_o}$$

G_v = flashing mass flux (lb/s \cdot ft²).

$$G_v = \frac{68.09 \{ -2 [\omega \ln \eta_v + (w - 1)(1 - \eta_v)] \}^{1/2}}{\omega \left(\frac{1}{\eta_v} - 1 \right) + 1} \sqrt{P_o / v_o}$$

Go to Step 7.

Step 6—Calculate the Mass Flux (ω calculated from Equation D.15)

For critical flow, use Equation D.20. For subcritical flow, use Equation D.21.

$$G = 68.09 \eta_c \sqrt{\frac{P_o}{v_o \omega}} \quad (D.20)$$

$$G = \frac{68.09 \{ -2 [\omega \ln \eta_a + (w - 1)(1 - \eta_a)] \}^{1/2}}{\omega \left(\frac{1}{\eta_a} - 1 \right) + 1} \sqrt{P_o / v_o} \quad (D.21)$$

where

G = mass flux (lb/s \cdot ft²).

η_a = back pressure ratio.

$$= \frac{P_a}{P_o}$$

Step 7—Calculate the Required Area of the PRV

$$A = \frac{0.04 W}{K_d K_b K_c G} \quad (D.22)$$

wherc

A = required effective discharge area (in.²).

W = mass flow rate (lb/hr).

K_d = discharge coefficient that should be obtained from the valve manufacturer. For a preliminary sizing estimation, a discharge coefficient of 0.85 can be used.

K_b = back pressure correction factor for vapor that should be obtained from the valve manufacturer. For a preliminary sizing estimation, use Figure D.2. The back pressure correction factor applies to balanced-bellows valves only.

K_c = combination correction factor for installations with a rupture disk upstream of the pressure relief valve (See 3.11.2).

= 1.0 when a rupture disk is not installed,

= 0.9 when a rupture disk is installed in combination with a pressure relief valve and the combination does not have a published value.

D.2.3.2 Example

In this example, the following relief requirements are given:

- Required gas oil hydrotreater (GOHT) flow rate caused by an operational upset of 153,830 lb/hr.
- Temperature at the PRV inlet of 450°F (909.67 R).
- Relief valve set at 600 psig, the design pressure of the equipment.
- Downstream total back pressure of 55 psig (69.7 psia) (superimposed back pressure = 0 psig, built-up back pressure = 55 psig).
- Two-phase specific volume at the PRV inlet of 0.1549 ft³/lb.
- Mass fraction of the vapor and gas at the PRV inlet of 0.5596.
- Combined specific volume of the vapor and gas at the PRV inlet of 0.2462 ft³/lb.
- Inlet gas mole fraction in the vapor phase of 0.4696. Non-condensable gases in the GOHT system include hydrogen, nitrogen, and hydrogen sulfide.
- Since the specific heat ratio k is unknown, a value of 1.0 will be used.

In this example, the following data are derived:

- Overpressure of 10%.
- Relieving pressure of $1.10 \times 600 = 660$ psig (674.7 psia).
- Percent of gauge back pressure = $(55/600) \times 100 = 9.2\%$. Since the downstream back pressure is less than 10% of the set pressure, a conventional pressure relief valve should be used. Thus, the back pressure correction factor $K_b = 1.0$.

Step 1—Calculate the Inlet Void Fraction, α ,

The inlet void fraction, α , is calculated from Equation D.13 as follows:

$$\alpha_o = \frac{0.5596 \times 0.2462}{0.1549}$$

$$= 0.8894$$

Step 2—Calculate the Omega Parameter, ω

Since the GOHT system has a nominal boiling range greater than 150°F, Equation D.15 is used to calculate the omega parameter ω . The specific volume evaluated at $0.9 \times 674.7 = 607.2$ psia using the results of an isenthalpic (adiabatic) flash calculation from a process simulator is

0.1737 ft³/lb. The omega parameter is calculated from Equation D.15 as follows:

$$\omega = 9 \left(\frac{0.1737}{0.1549} - 1 \right)$$

$$= 1.092$$

Step 4—Determine if the Flow is Critical or Subcritical

The critical pressure ratio, η_c , is 0.62 (from Figure D.1 using $w = 1.092$). This ratio can also be obtained from the following expression:

$$\eta_c^2 + (\omega^2 - 2\omega)(1 - \eta_c)^2 + 2\omega^2 \ln \eta_c + 2\omega^2(1 - \eta_c) = 0$$

The critical pressure P_c is calculated as follows:

$$P_c = 0.62 \times 674.7$$

$$= 418.3 \text{ psia}$$

The flow is determined to be critical since $P_c > P_a$.

$$418.3 > 69.7$$

Step 6—Calculate the Mass Flux, G

The mass flux G is calculated from Equation D.20 as follows:

$$G = 68.09 \times 0.62 \sqrt{\frac{674.7}{0.1549 \times 1.092}}$$

$$= 2666 \text{ lb/s} \cdot \text{ft}^2$$

Step 8—Calculate the Required Area of the PRV

The required area of the PRV is calculated from Equation D.22 as follows:

$$A = \frac{0.04 \times 153,830}{0.85 \times 1 \times 1 \times 2666}$$

$$= 2.72 \text{ in.}^2$$

Select an "L" orifice pressure relief valve (2.853 in.²).

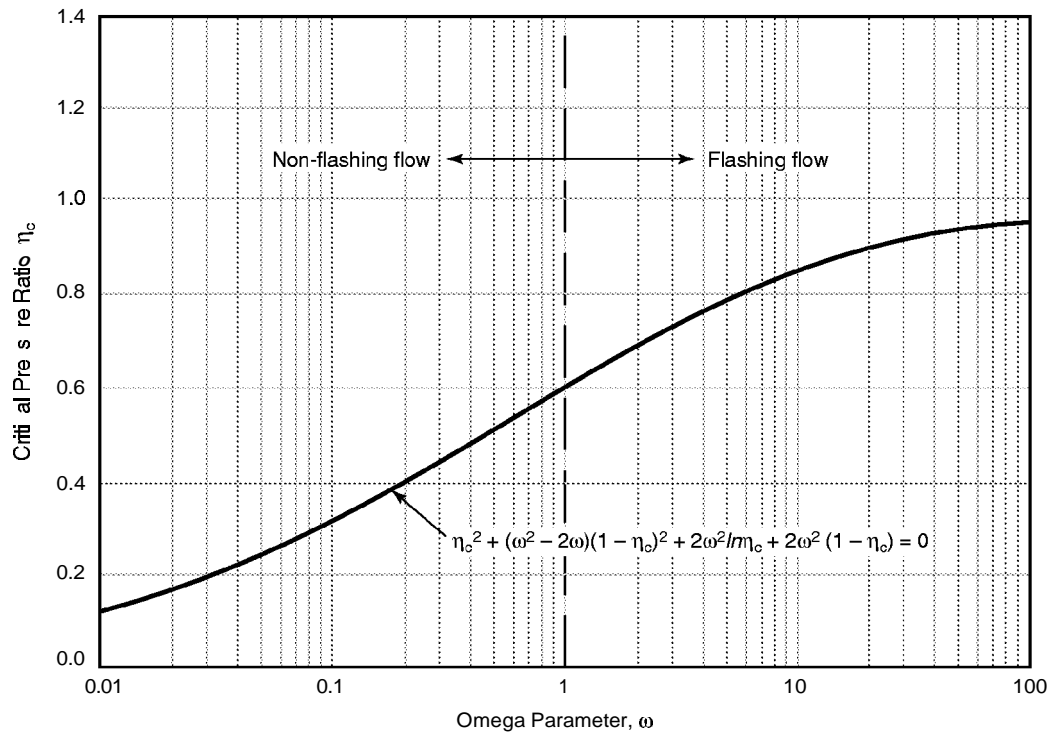
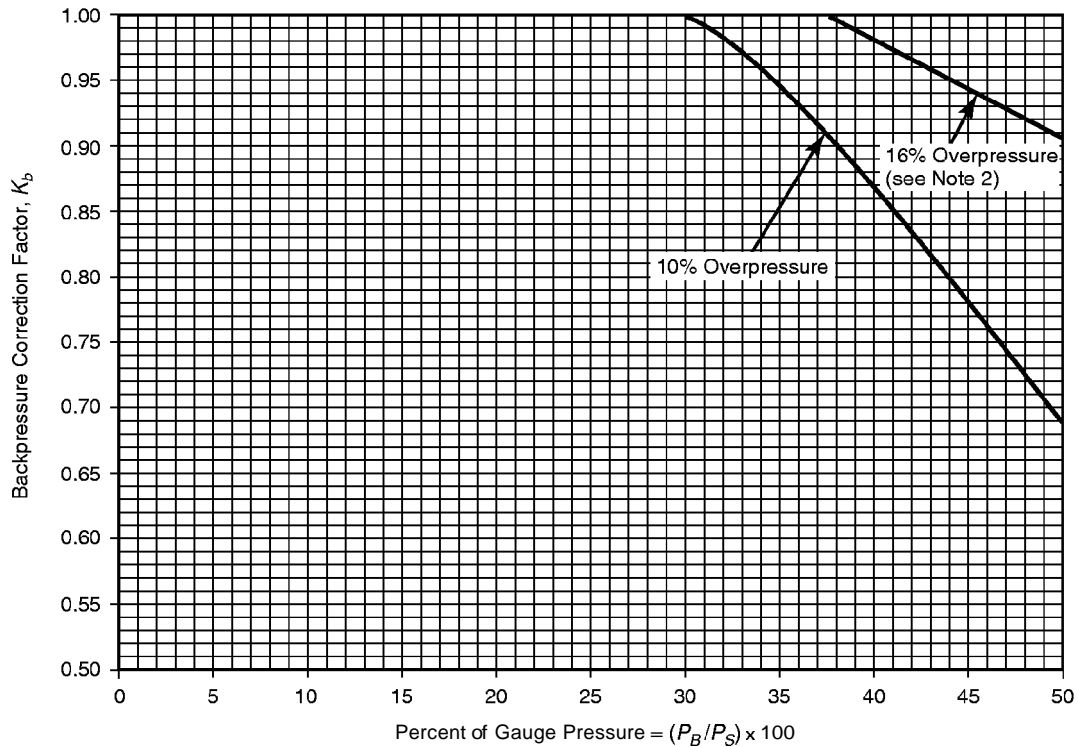

Figure D-1 — Correlation for Nozzle Critical Flow of Flashing and Nonflashing Systems



P_B = back pressure, in psig.
 P_S = set pressure, in psig.

Notes:

1. The curves above represent a compromise of the values recommended by a number of relief valve manufacturers and may be used when the make of the valve or the critical flow pressure point for the fluid is unknown. When the make of the valve is known, the manufacturer should be consulted for the correction factor. These curves are for set pressures of 50 psig and above. They are limited to back pressure below critical flow pressure for a given set pressure. For set pressures below 50 psig or subcritical flow, the manufacturer must be consulted for values of K_b .
2. See paragraph 3.3.3.
3. For 21% overpressure, K_b equals 1.0 up to $P_B/P_S = 50\%$.

Figure D-2—Back Pressure Correction Factor, K_b , for Balanced-Bellows Pressure Relief Valves (Vapors and Gases)

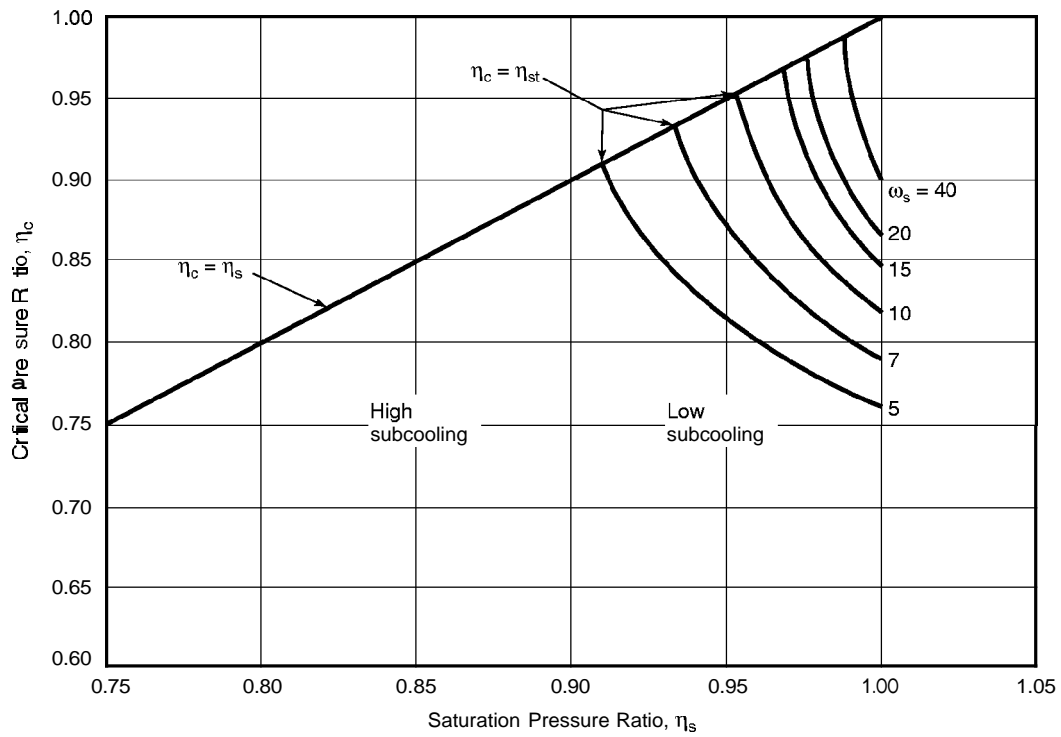
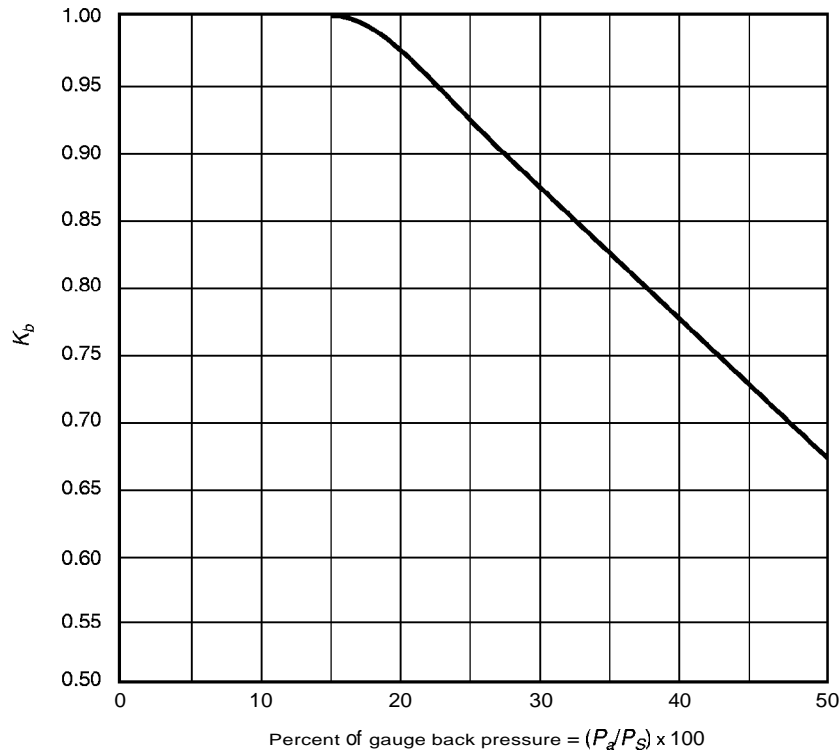

Figure D-3—Correlation for Nozzle Critical Flow of Inlet Subcooled Liquids



K_b = correction factor due to back pressure.

P_a = back pressure, in psig.

P_s = set pressure, in psig.

Note: The curve above represents values recommended by various manufacturers. This curve may be used when the manufacturer is not known. Otherwise, the manufacturer should be consulted for the applicable correction factor.

Figure D-4--Back Pressure Correction Factor, K_b , for Balanced-Bellows Pressure Relief Valves (Liquids)

APPENDIX E—CAPACITY EVALUATION OF RUPTURE DISK AND PIPING SYSTEM 100% VAPOR FLOW AND CONSTANT PIPE DIAMETER

E.1 General

E.1.1 The following method can be used to estimate the vapor capacity of a rupture disk/piping system of constant diameter. The method is based on compressible pipe flow equations contained in Crane Technical Paper No. 410—"Flow of Fluids Through Valves, Fittings, and Pipe," and the application of standard resistance factors (*K* values) from API RP 521.

E.1.2 The method assumes that C_p/C_v is equal to 1.4. This assumption provides conservative results. The method can be applied to a piping system with varying diameters by treating each section of constant diameter separate.

E.1.3 The method presented in Crane No. 410 is based on graphical evaluation of several parameters. Curve fits of the graphical data are also presented below to allow direct solution without the graphical data. The use of the curve fitting equations introduces negligible error relative to the accuracy of the *K* factors.

E.2 Example Problem

Figure E-1 shows the arrangement of the vessel and rupture disk/piping system for the example problem.

Step 1—Determine Required Information

- a. MAWP = 100 psig.
- b. P_1 = relieving pressure = 110% = 124.7 psia.
- c. T_1 = relieving temperature = 200°F + 460°F = 660 R.
- d. Z_1 = relieving compressibility = 1.0.
- e. M_w = molecular weight = 20.0.
- f. P_2 = back pressure = 14.7 psia.

Step 2—Determine Overall Piping Resistance Factor, *K*

Description	<i>K</i> Value	Source of <i>K</i> Value Data
Slightly Rounded Entrance	0.50	Crane 410, Page A29
Rupture Disk	1.50	API 521, Table 11
15' 3" Schedule 40 Pipe	1.04	$K = fL/D$; $f = 0.0178$ (API 521, Table 12) $L = 15$ ft $D = 3.068"/12 = 0.2557$ ft
Sudden Expansion	1.00	API 521, Table 11
Total System <i>K</i>	4.04	

Step 3—Determine Y_{sonic} and dP_{sonic}/P_1 Based on Total System *K*

This step is based on the Crane 410 A-22 Chart Method for Obtaining Y_{sonic} and dP_{sonic}/P_1 . From chart and table on A-22 for $k (C_p/C_v) = 1.4$.

$$Y_{sonic} = 0.65$$

$$dP_{sonic}/P_1 = 0.70$$

As an alternate to the chart method, a curve fit of Crane 410 A-22 Chart for Obtaining Y_{sonic} and dP_{sonic}/P_1 has been provided:

For dP_{sonic}/P_1 :

$$\text{If } 1.2 < K \leq 10, \text{ then } dP_{sonic}/P_1 = 0.1107 \ln(K) + 0.5352$$

$$\text{If } 10 < K \leq 100, \text{ then } dP_{sonic}/P_1 = 0.0609 \ln(K) + 0.6513$$

For Y_{sonic} :

$$\text{If } 1.2 < K \leq 20, \text{ then } Y_{sonic} = 0.0434 \ln(K) + 0.5889$$

$$\text{If } 20 < K \leq 100, \text{ then } Y_{sonic} = 0.710$$

Based on $K = 4.04$:

$$dP_{sonic}/P_1 = 0.69$$

$$Y_{sonic} = 0.65$$

Step 4—Compare dP_{sonic}/P_1 to dP_{actual}/P_1

$$dP_{actual}/P_1 = (124.7 \text{ psia} - 14.7 \text{ psia})/124.7 \text{ psia} = 0.88$$

Since $dP_{sonic}/P_1 < dP_{actual}/P_1$, the flow will be sonic (critical). Use Y_{sonic} and dP_{sonic}/P_1 and skip to Step 6 (if subsonic, proceed to Step 5).

Step 5—Evaluate Y_{actual} (Subsonic Cases Only)

Using the Crane 410 A-22 Chart Method to obtain Y_{actual} :

a. At dP_{actual}/P_1 and *K* determine Y_{actual} from the A-22 Chart.

b. Use dP_{actual}/P_1 and Y_{actual} in Step 6.

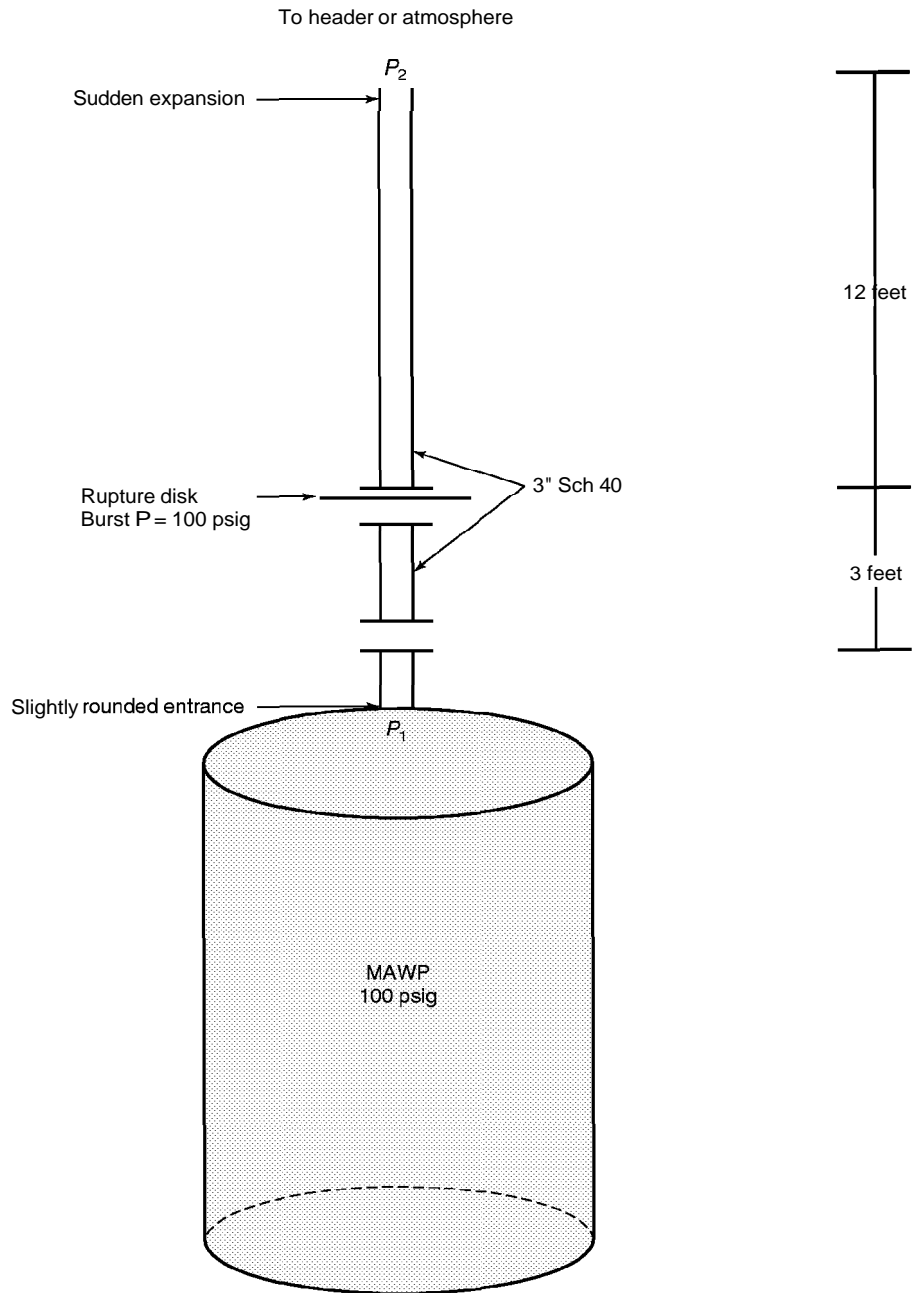

Figure E-1 — Pressure Relief System for Example Problem

Using the Curve Fit Method for Obtaining Y_{actual} :

a. Calculate Y_{actual} from the following equation:

$$Y_{actual} = 1 - \frac{(1 - Y_{sonic})}{dP_{sonic}/P_1} \left(\frac{dP_{actual}}{P_1} \right)$$

b. Use dP_{actual}/P_1 and Y_{actual} in Step 6 in place of dP_{sonic}/P_1 and Y_{sonic} .

Step 6—Calculate Capacity Based on Crane 410 Equation 3-20

$$W = 0.9 \left[1891 Y d^2 \sqrt{\frac{dP}{K V_1}} \right]$$

Using the Chart Method Values:

- a. $Y = Y_{sonic} = 0.65$.
- b. $d = \text{Pipe ID (inches)} = 3.068 \text{ inches}$.
- c. $dP = (dP_{sonic}/P_1)(P_1) = 87.3 \text{ psi}$.
- d. $K = \text{Overall resistance} = 4.04$.
- e. $V_1 = \text{Vapor specific volume} = 2.84 \text{ ft}^3/\text{lb}$ (Obtained using ideal gas law and compressibility) $W = 28,720 \text{ lb/hr}$.

Using the Curve Fit Method Values:

- a. $Y = Y_{sonic} = 0.65$.
- b. $d = \text{Pipe ID (inches)} = 3.068 \text{ inches}$.
- c. $dP = (dP_{sonic}/P_1)(P_1) = 86.0 \text{ psi}$.
- d. $K = \text{Overall resistance} = 4.04$.
- e. $V_1 = \text{Vapor specific volume} = 2.84 \text{ ft}^3/\text{lb}$ (Obtained using ideal gas law and compressibility) $W = 28,508 \text{ lb/hr}$.

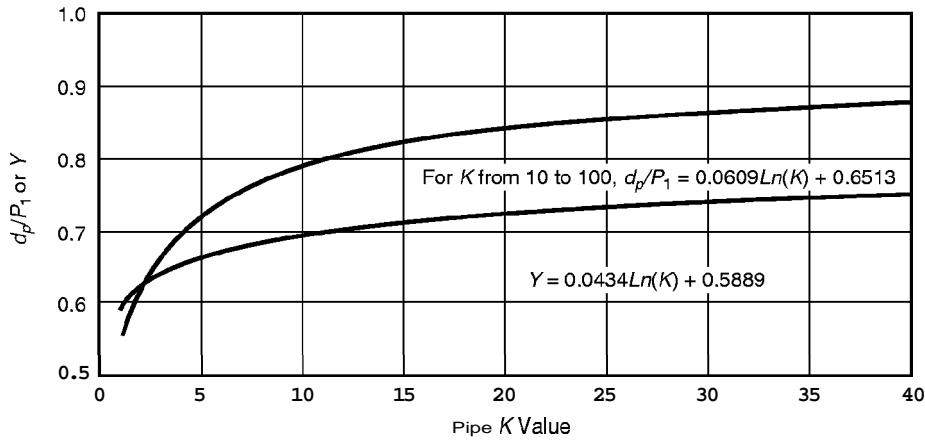

Figure E-2—Curve Fit for $C_p/C_v = 1.4$ (Crane Figure A-22)

The American Petroleum Institute provides additional resources and programs to industry which are based on API Standards. For more information, contact:

- Training/Workshops Ph: 202-682-8564
Fax: 202-962-4797
- Inspector Certification Programs Ph: 202-682-8161
Fax: 202-962-4739
- American Petroleum Institute
Quality Registrar Ph: 202-682-8574
Fax: 202-682-8070
- Monogram Licensing Program Ph: 202-962-4791
Fax: 202-682-8070
- Engine Oil Licensing and
Certification System Ph: 202-682-8233
Fax: 202-962-4739

To obtain a free copy of the API Publications, Programs, and Services Catalog, call 202-682-8375 or fax your request to 202-962-4776. Or see the online interactive version of the catalog on our web site at www.api.org/cat.



**Helping You
Get The Job
Done Right.SM**

10.1.99

API Related Publications Order Form - 2000

Date _____
(Month, Day, Year)

API Member
(Check if Yes)

Invoice To – Check here if same as "Ship To"

Ship To – (UPS will not deliver to a PO Box)

Company: _____

Company: _____

Name/Dept: _____

Name/Dept: _____

Address: _____

Address: _____

City: _____ State/Province: _____

City: _____ State/Province: _____

Zip: _____ Country: _____

Zip: _____ Country: _____

Customer Daytime Telephone No: _____

Customer Daytime Telephone No: _____

Fax No: _____

Fax No: _____

(Essential for Foreign Orders)

(Essential for Foreign Orders)

Payment Enclosed \$ _____

Please Bill Me

Payment By Charge Account:

PO No: _____

MasterCard VISA American Express

Customer Account No: _____

Account No: _____

State Sales Tax – The American Petroleum Institute is required to collect sales tax on publications mailed to the following states: AL, AR, CT, DC, HI, GA, IL, IN, IA, KS, KY, ME, MD, MA, MI, MN, MO, NE, NJ, NY, NC, ND, OH, PA, RI, SC, TN, TX, VT, VA, WV and W. Prepayment of orders shipped to these states should include applicable sales tax unless a purchaser is exempt. If exempt, please print your state exemption number and enclose a copy of the current exemption certificate.

Exemption Number: _____ State: _____

Name (As It Appears on Card): _____

Expiration Date: _____

Signature: _____

Quantity	Order Number	Title	SO*	Unit Price	Total
	C52024	RP 520, <i>Sizing Selection, and Installation of Pressure-Relieving Devices in Refineries, Part II—Installation</i>		\$ 55.00	
	C52104	RP 521, <i>Guide for Pressure-Relieving and Depressuring Systems</i>		\$ 120.00	
	C52604	Std 526, <i>Flanged Steel Pressure Relief Valves</i>		\$ 70.00	
	C52700	Std 527, <i>Seat Tightness of Pressure Relief Valves</i>		\$ 40.00	
	C20005	Std 2000, <i>Venting Atmospheric and Low-Pressure Storage Tanks: Nonrefrigerated and Refrigerated</i>		\$ 75.00	
				Subtotal	
				State Sales Tax (see above)	
				Rush Shipping Charge (see left)	
				Shipping and Handling (see left)	
				Total (in US Dollars)	

Shipping and Handling – All orders are shipped via UPS or First Class Mail in the US and Canada. Orders to all other countries will be sent by Airmail. US and Canada, \$5 per order handling fee, plus actual shipping costs. All other countries, \$15 per order handling fee, plus actual shipping costs.

Rush Shipping Charge – FedEx, \$10 in addition to customer providing FedEx account number: _____, UPS Next Day \$10 plus the actual shipping costs (1-9 items), UPS Second Day add \$10 plus the actual shipping costs (1-9 items).

Rush Bulk Orders – 1-9 items, \$10. Over 9 items, add \$1 each for every additional item. *NOTE: Shipping on foreign orders cannot be rushed without FedEx account number.*

Returns Policy - Only publications received in damaged condition or as a result of shipping or processing errors, if unstamped and otherwise not defaced, may be returned for replacement within 45 days of the initiating invoice date. A copy of the initiating invoice must accompany each return. Material which has neither been damaged in shipment nor shipped in error requires prior authorization and may be subject to a shipping and handling charge. **All returns must be shipped prepaid using third class postage.** If returns are due to processing or shipping errors, API will refund the third class postage.

* To be placed on Standing Order for future editions of this publication, place a check mark in the space provided.

Pricing and availability subject to change without notice.

Mail Orders American Petroleum Institute, Order Desk, 1220 L Street, NW, Washington, DC 20005-4070, USA
 Fax Orders 202-962-4776 Phone Orders 202-682-8375

To better serve you, please refer to this code when ordering: **L A 4 5 0 9 0 2 0 0**

Additional copies available from API Publications and Distribution:
(202) 682-8375

Information about API Publications, Programs and Services is
available on the World Wide Web at: <http://www.api.org>



**American
Petroleum
Institute**

1220 L Street, Northwest
Washington, D.C. 20005-4070
202-682-8000

Order No. C52017